

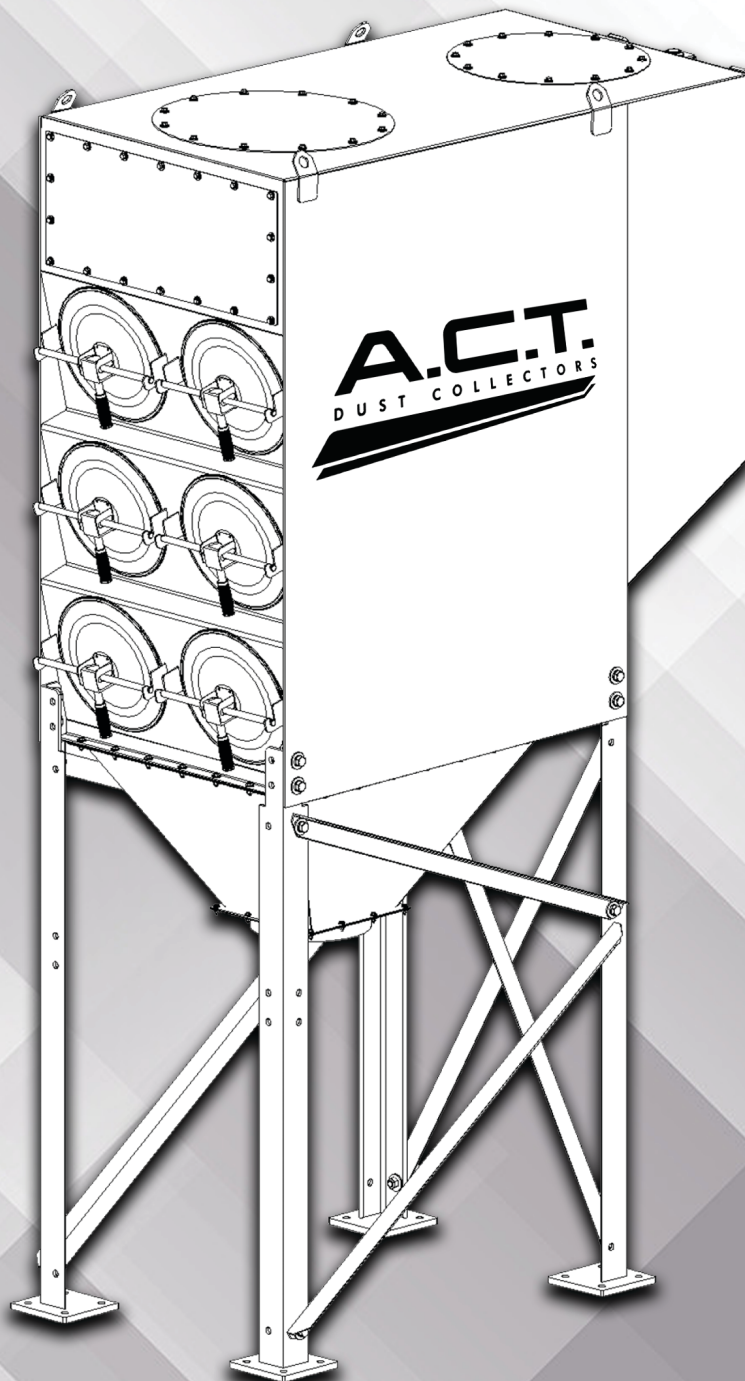

Installation and Operation Manual



763-557-7162

info@actdustcollectors.com

820 North Front Street, New Ulm, MN 56073



Product Data Sheet

Purchaser: _____

Order date: _____

A.C.T. Dust Collector Model: _____

Serial Number: _____

Filters: _____

Option/Accessories: _____

Fan/Blower

Manufacturer/Model: _____

Serial Number: _____

CAUTION!

Accidents happen, be careful and always follow all local and federal regulations!

Fires and explosions do occur in dust collectors. Many items in a dust form can become very flammable and/or explosive. It is very important that when installing a dust collector to check with and abide by all local and federal regulations. Precautions such as spark traps, detectors, and extinguishers are always recommended when sparks or explosive danger is present. Never throw any burning objects into the duct work or dust collector.

There is no way to guarantee 100% prevention of fires. However, the methods mentioned above will greatly reduce your risk. A.C.T. Dust Collectors will not be responsible in any way for any loss or damage associated with fires or explosions in your dust collector.

If your dust collector came with explosion vents or if explosive dusts are present, it is the owner's/operator's responsibility for full compliance with all authorities having jurisdiction. It is recommended that the NFPA codes be studied and applied, including, but not limited to 68, 69 and 654. Included in the NFPA standards is the issue of isolating your dust collector. Please contact us or an expert in the area regarding isolation of your dust collector in the event of an explosion. Unless a Kst test was performed, and we were provided with the results, the size of the explosion vents may be inaccurate and you may not be in compliance. It is the owner/operators responsibility to verify the Kst and Pmax values. We recommend that your process be evaluated regularly to make sure that you remain in compliance and the vent area is sufficient. A.C.T. Dust Collectors will not be responsible for ANY loss whatsoever resulting from an explosion associated with an ACT dust collector.

Dust collectors are tall and top heavy. Always be careful when handling them. Make sure your equipment is capable of making the lifts and moves you are trying to make. Be sure the foundation for the dust collector is proper and secure.

All plumbing and electrical should be performed by certified professionals and meet all codes and regulations. Never open any doors or access panels while the machine is in operation.

Always shut down the unit prior to service and lock out all disconnects.

Always wear proper safety equipment when working on or around your dust collector and follow all local and federal codes.

Table of Contents

| | |
|--|----|
| Product Data Sheet | 1 |
| Caution Notice..... | 2 |
| Introduction..... | 4 |
| Operation Principle..... | 5 |
| Shipping and Receiving..... | 6 |
| Handling..... | 6 |
| Assembly | |
| Housing, Hopper, and Legs..... | 7 |
| Flex Hose, Drum Lid, and Optional Drum Lid Latch Ring Kit..... | 8 |
| Top Mounted Fan..... | 9 |
| Compressed Air..... | 10 |
| Electrical..... | 11 |
| Timer Board Programming..... | 14 |
| Start-up Process | 15 |
| Maintenance | |
| Filter Replacement..... | 16 |
| Dust Drawers..... | 17 |
| Spare Parts..... | 18 |
| Optional Additions | 19 |
| Preventative Maintenance..... | 22 |
| Troubleshooting..... | 23 |

Introduction

Thank you for your purchase of an A.C.T. Dust Collectors unit. Our goal is to provide you with a product of best quality, service, and pricing in the industry.

This manual is to provide general instructions in assisting you with the installation, operation, and maintenance of your equipment. It is the user's responsibility to ensure that the equipment is correctly installed and operated. It is also the user's responsibility to ensure and provide qualified personnel for the installation, operation, and maintenance of the equipment and to adhere to all applicable federal and local building and safety codes and regulations.

Any special instructions and certified drawings accompanying this equipment shall supersede this manual.

Keep this manual along with any special instructions and drawings necessary for assembly, operation, and maintenance with the equipment.

Recommended Tools for Install



- Drill
- Impact
- 9/16" Socket
- 9/16" Wrench
- 1 1/8" Socket
- 1 1/8" Wrench
- Anchoring Kit
- Ladder
- Lifting Chains/Straps

Operation Principle

The A.C.T. cartridge dust collector has a pulse-jet air cleaning device that removes the particulates from dust-laden air and allows clean air to be exhausted. As dust enters through the dirty air inlet, the heavier particulates fall down into the hopper while the remaining fine dust is collected on the cartridge filters, allowing clean air to be passed through the filters and then exhausted.

To remove excess dust buildup on the filters, a timer board is used to sequentially open the diaphragm valves and release a pulse of compressed air. This venturi-assisted pressure pulse releases the accumulated dusts on the filters, allowing the particulate to drop down into the hopper.

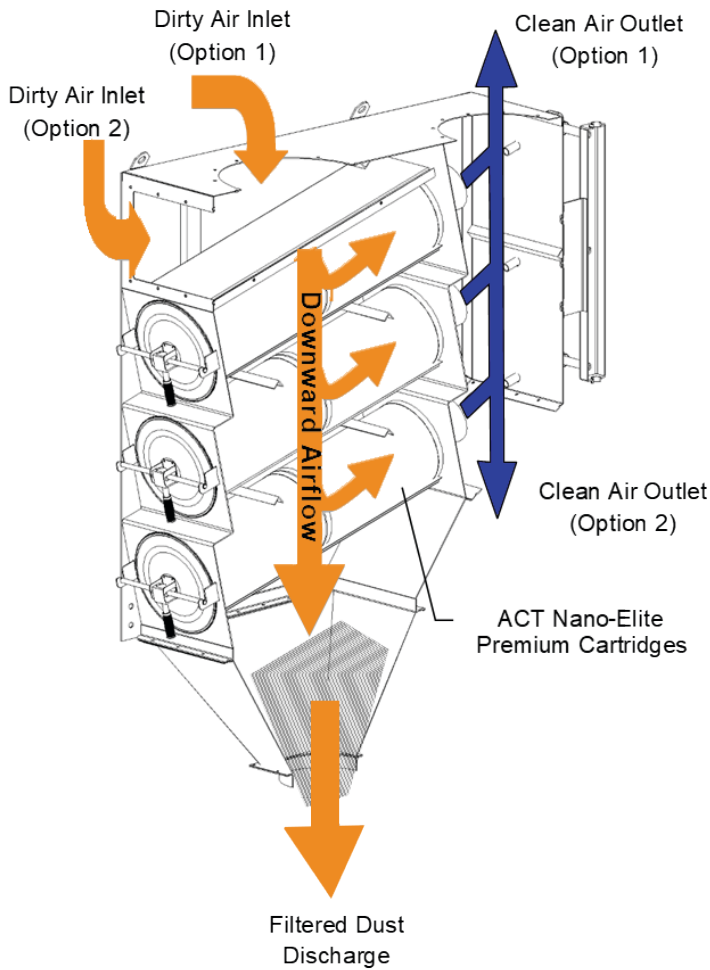

Dust Filtration Process

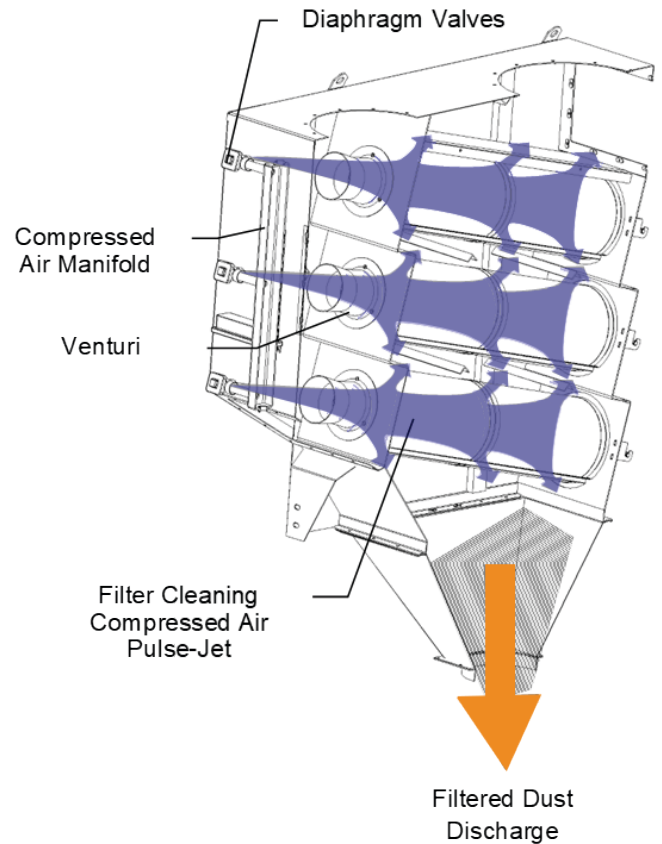

Pulse-Jet Cleaning Process

Shipping and Receiving

All products from A.C.T. Dust Collectors are carefully inspected for quality and order completion prior to shipment.

Prior to unloading, inspect all components for any shipping damage and missing parts. Report and file a claim immediately with the carrier for any damage or missing items. Once filed, contact your A.C.T. Dust Collectors representative to notify them of the issue(s).

Any repairs to components with minor damage from transit must be approved in writing by the manufacturer.

Handling

Handling should be performed by trained, able, and qualified personnel and be consistent with safe handling practices outlined by OSHA and local codes.

Review this manual and any additionally supplied certified drawing(s) to familiarize yourself with the lift points of each of the components.

Verify the integrity and lift capacity of all handling equipment/components.

When handling the housing, it is recommended to utilize spreader bars to prevent any deformation during lifting. All lifting points are to be used.

Table 1 - Recommended SAE Torque Table

| Bolt Size | SAE Grade 5 Torque (ft-lb), dry |
|-----------|---------------------------------|
| 1/4-20 | 8.4 |
| 5/16-18 | 17.4 |
| 3/8-16 | 31 |
| 7/16-14 | 49 |
| 1/2-13 | 75 |
| 5/8-11 | 150 |
| 3/4-10 | 267 |

Assembly

Dust Collector Housing and Legs

1. Using all lifting lugs, raise the dust collector housing with a crane to allow enough clearance to fasten the legs.
2. (Do Not lift using the compressed air manifold).
3. Fasten the legs with the supplied hardware. Hand tighten the hardware and keep the collector supported with the crane. For BIBO units, install hopper prior to legs.
4. Install the hopper. Apply sealing tape to the hopper flange on the inner side of the hopper bolt pattern.
5. Locate and fasten the leg bracings to the legs.
6. Hand tighten the hardware.
7. If applicable, fasten the middle of the leg bracings that cross one another.
8. Anchor the legs to the concrete pad using $\frac{3}{4}$ " diameter anchors. Install $\frac{3}{4}$ " diameter anchor bolts with a minimum $1 \frac{3}{4}$ " extension above the foundation.
9. Ensure foundation complies with all local codes and regulations.
10. Once the legs have been assembled and anchored, tighten all of the fasteners to the recommended SAE torque per Table 1. (On Page 6)

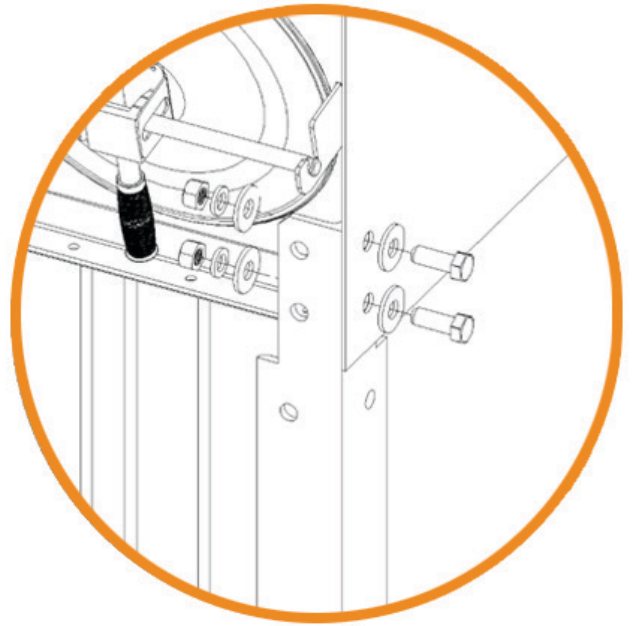

Legs Installation - Detail A

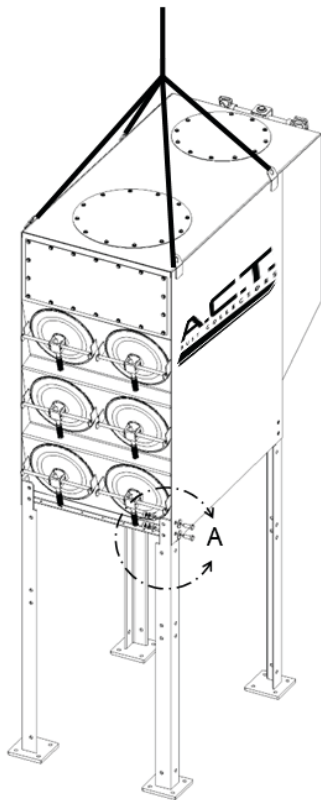

Legs Installation

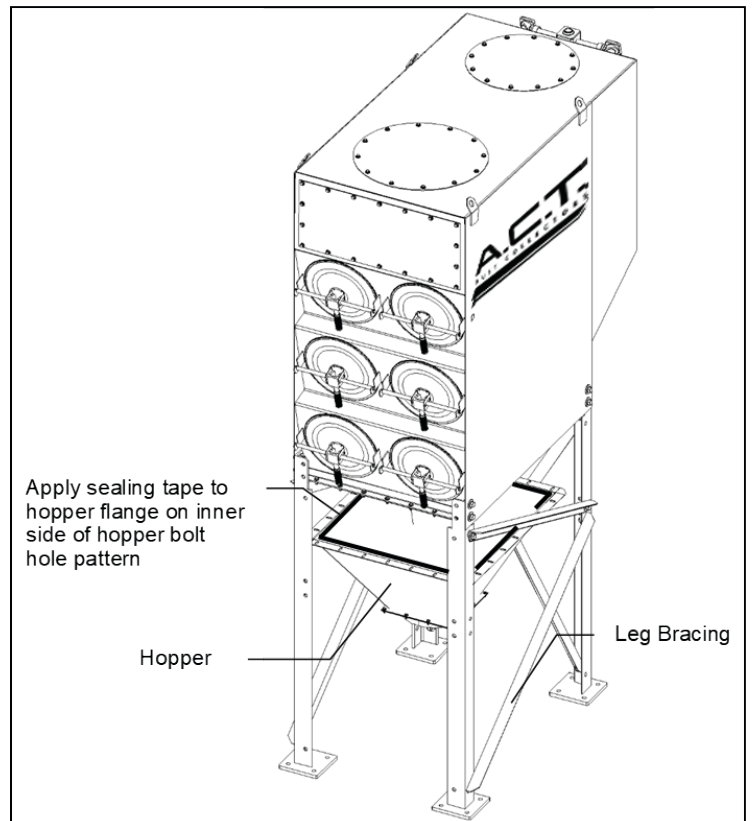

Leg Bracing and Hopper Installation

Flex Hose and Drum Lid

The hopper outlet must be sealed in order for the collector to function properly by preventing air from being pulled through from the hopper outlet.

1. Secure the drum lid to the hopper outlet collar using the supplied flex hose and hose clamps.
2. Place drum lid on top of the drum barrel.

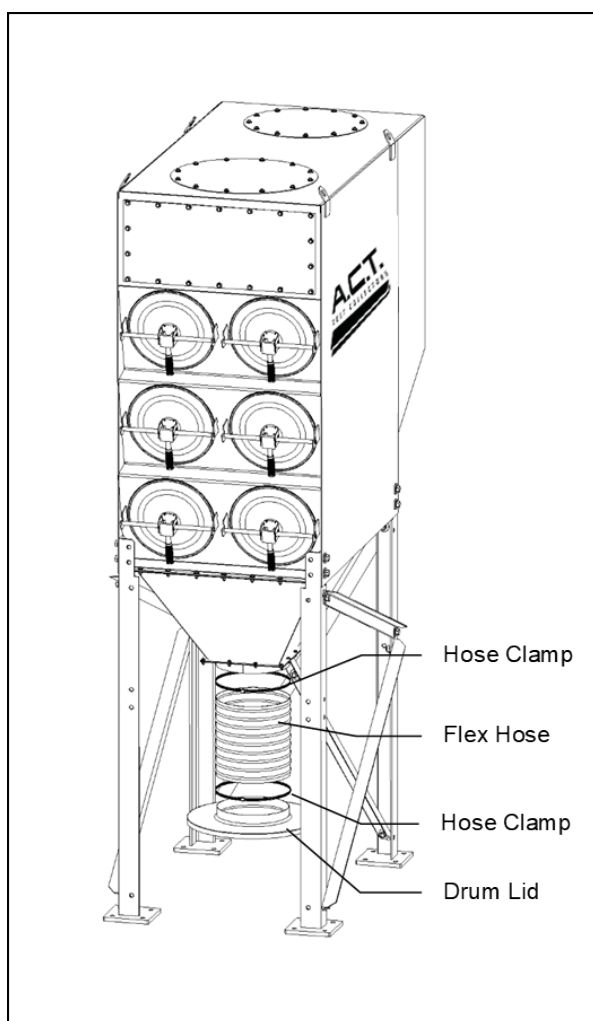

Flex Hose and Drum Lid Installation

Flex Hose, Drum Lid, with Optional Drum Lid Latch Ring Kit

An optional drum lid latch ring is available to help secure the drum lid on to the drum barrel.

1. Place the drum lid on top of a 55 gallon drum.
2. Place the drum lid latch ring over the drum lid and secure the lid by adjusting the four knobs.
3. Attach the flex hose to the drum lid and hopper collar using the hose clamps.

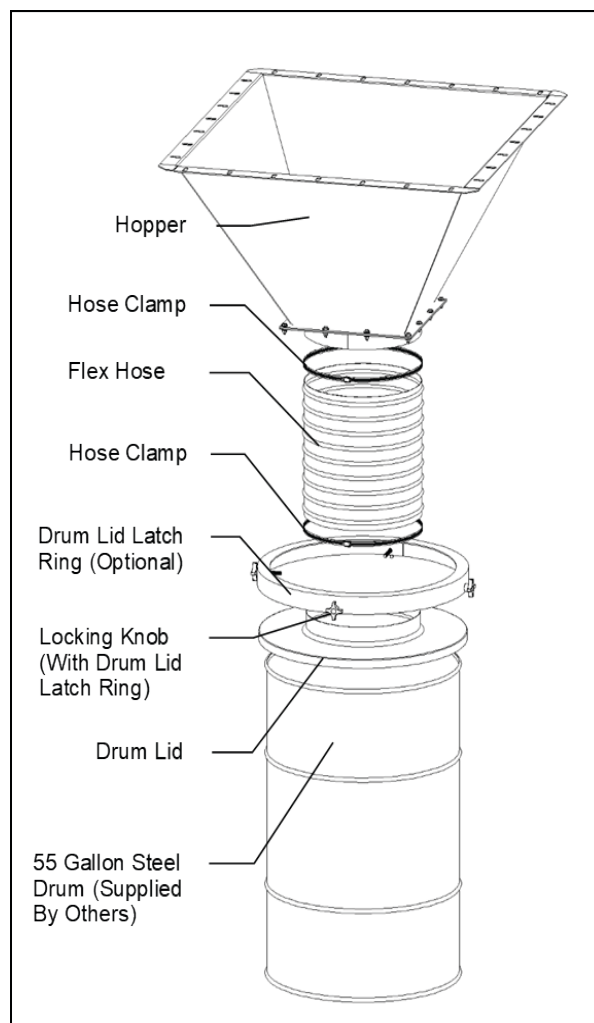

Flex Hose, Drum Lid, and with Optional Drum Lid Latch Ring Installation

Top Mounted Fan Installation

Standard fan model is shown below. Refer to the fan manual for other fan models.

1. The dust collector must be securely anchored prior to installing a top mount fan.
2. Remove the top outlet cover.
3. Apply sealing tape (or a bead of sealant) on to the inside of the bolt hole pattern.
4. With a crane (or proper lifting device), raise the fan blower using all designated lift points.
5. Place the fan blower onto the top of the dust collector, exhausting in desired direction, and secure with the supplied hardware.
6. All fan outlet silencers require additional support in the field (by others).

When setting the fan on the top use a screw driver to align the bolt holes for easy install.

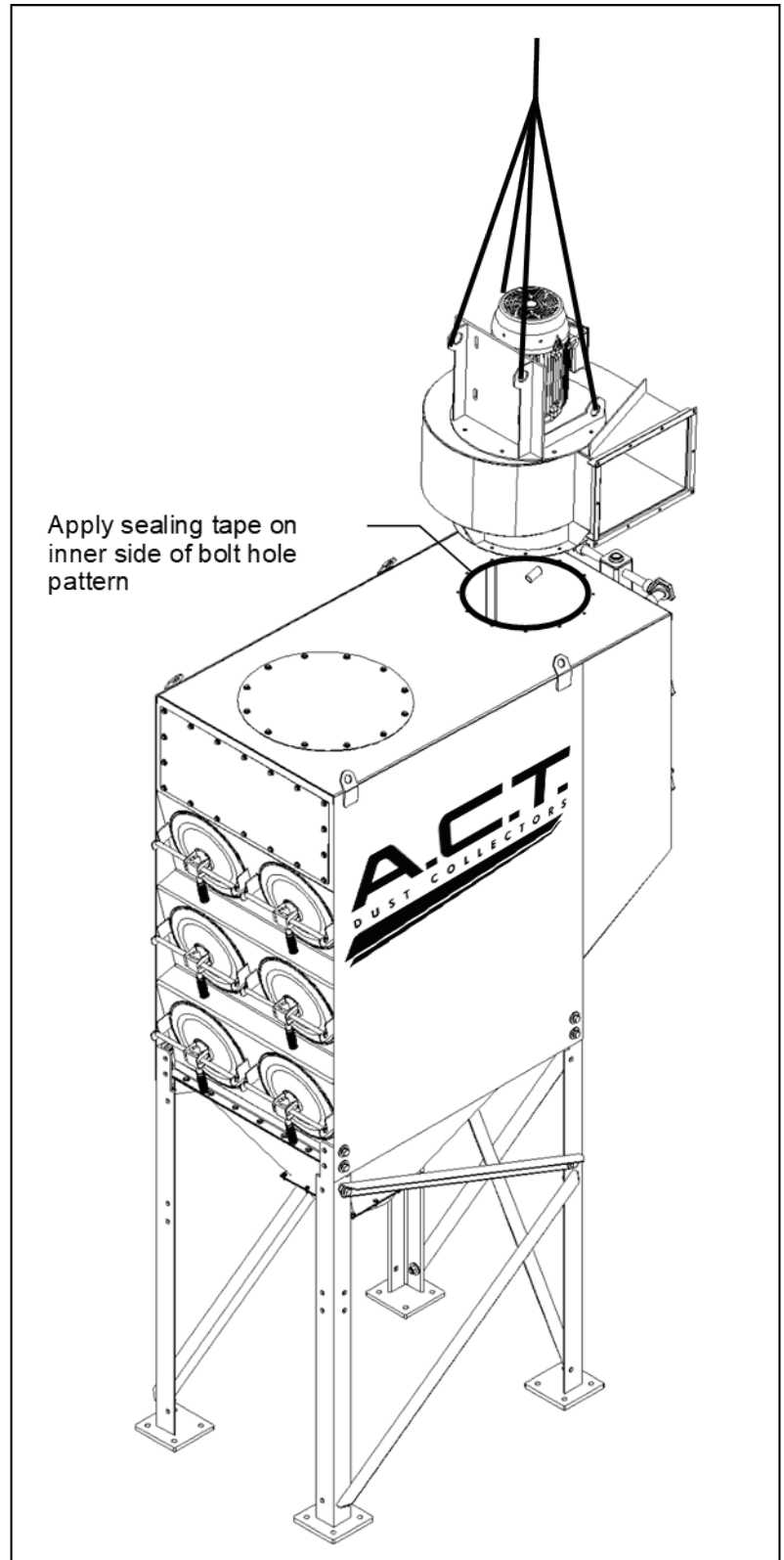

Top Mount Fan Installation

Compressed Air

The supplied compressed air must be clean, dry, and oil-free. Set the compressed air pressure levels to 90-100 psi. Do NOT exceed 100 psi as damage may occur to the components.

Prior to installation, purge the compressed air lines of any dirt or buildup.

1. Install the compressed air pipe line to the air manifold to either the top or bottom 1" NPT cou-

pling. Use thread sealant tape or compound on all connections.

2. A drip tee or ball valve installed on the bottom of the manifold is recommended to allow for the draining of any water buildup.
3. It is also recommended to install a shut-off valve, pressure regulator, safety exhaust valve, and filter close to the collector.

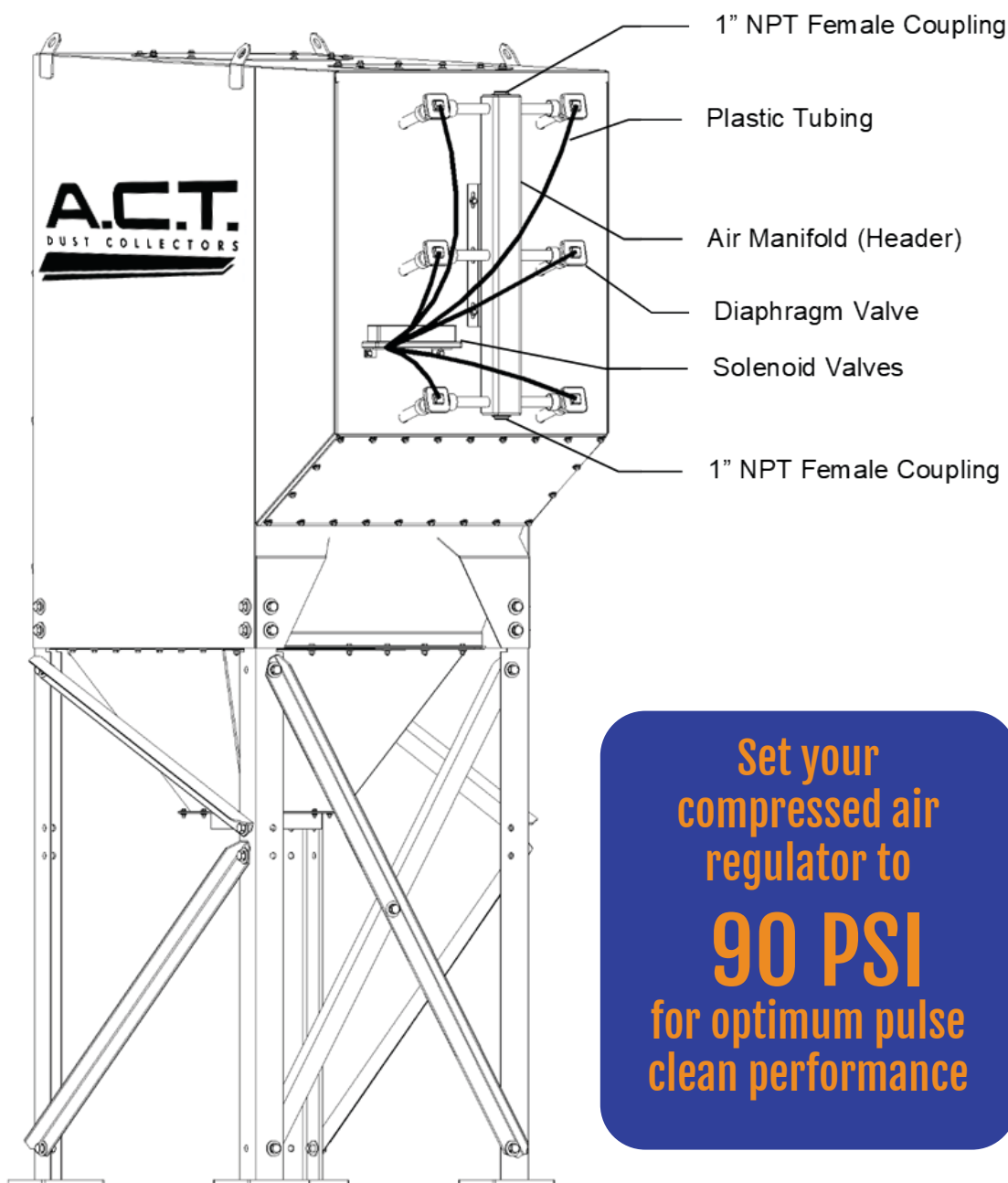

Electrical

All wiring should be done by a certified electrician and in accordance with all local and federal codes.

Refer to the job specific electrical drawing(s) located in the panel and manual binder for detailed instructions.

Fan and timing board/solenoid wiring are to be in separate conduits.

1. **Fan**

- Verify fan rotation by observing from the motor end. Another indication is poor fan performance or a lack of air movement.

2. **Timer Board**

- Locate the timer board as close to the dust collector as possible.
- To wire the timer board, please refer to the wiring diagram located inside the timer board enclosure.
- Once the timer board has been installed, the pressure gauge must be connected to the dust collector using customer supplied ¼" tubing (see figure on Page 12 for low and high pressure

ports).

If the dust collector is installed outside, the tubing should UV resistant.

- **IMPORTANT:** Prior to operating the dust collector or adjusting the settings, ensure that the down time clean feature has been properly wired. This feature will allow the dust collector to clean itself during shut down, which will aid in prolonging the life of the filters.

Electrical

All wiring should be done by a certified electrician and in accordance with all local and federal codes.

Refer to the job specific electrical drawing(s) located in the panel and manual binder for detailed instructions. Fan and timing board/solenoid wiring are to be in separate conduits.

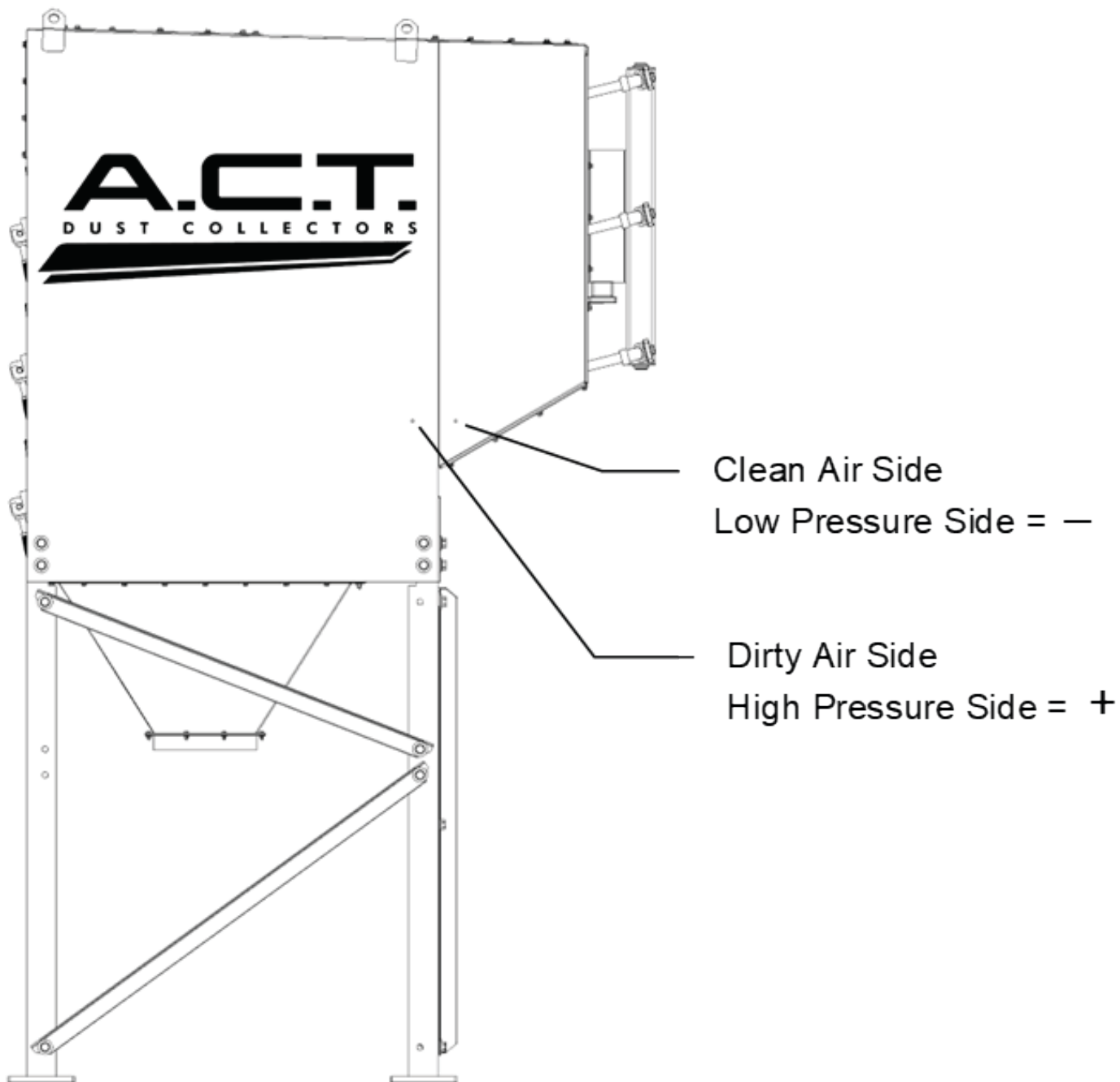

On the following page is an example of a basic electrical setup.

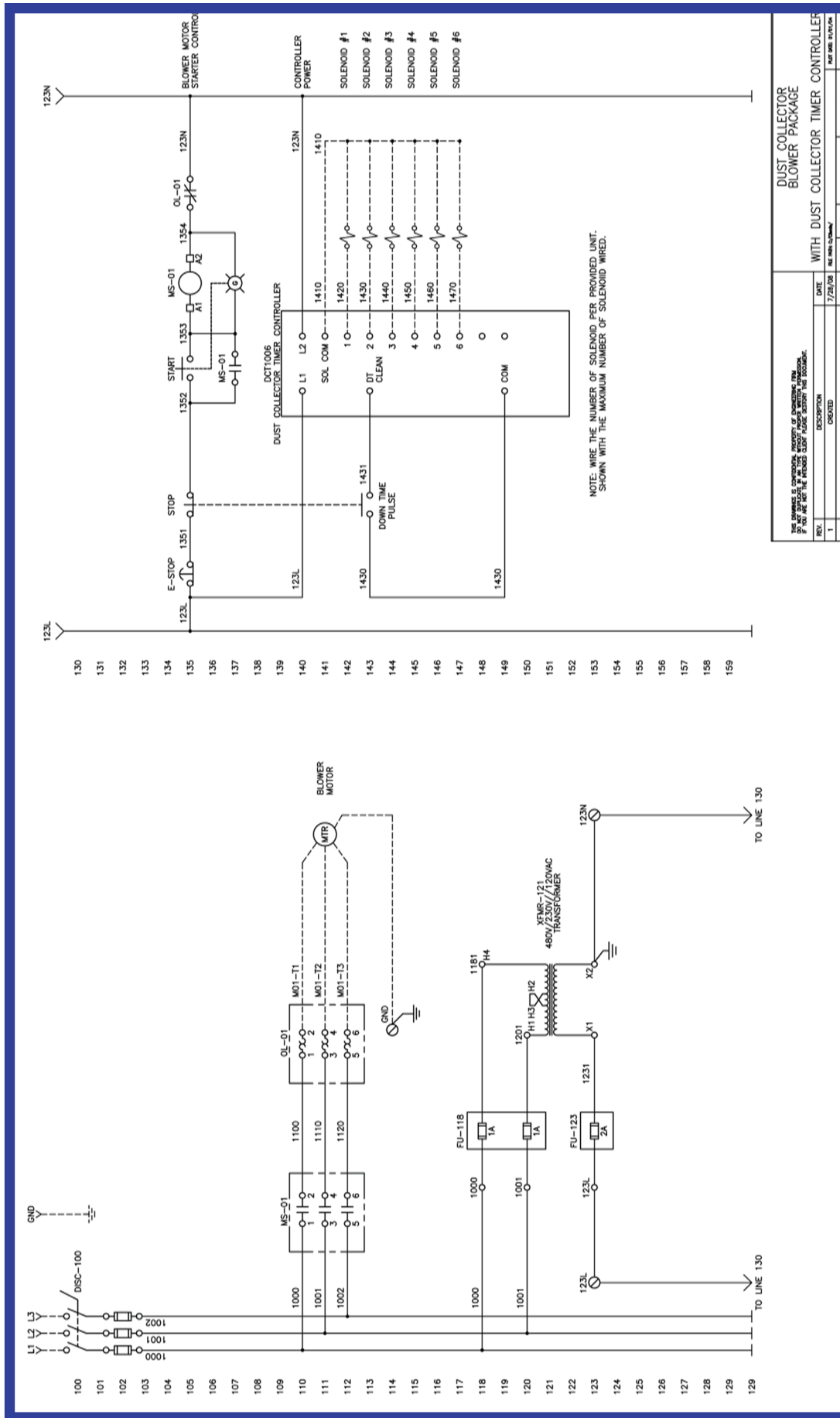

| DUST COLLECTOR BLOWER PACKAGE | |
|--------------------------------------|-----------|
| WITH DUST COLLECTOR TIMER CONTROLLER | |
| REV. | DATE |
| 1 | 7/25/08 |
| DESCRIPTION | REV. DATE |
| REVISED | 08/01/08 |

Timer Board Programming

Familiarize yourself with the timer board manual before programming the timer board.

The table below summarizes the recommended settings. Consult with A.C.T. Dust Collectors for specific applications.

Table 2 – Recommended Timer Board Settings

| Feature | Settings |
|------------------|--|
| Process | Current pressure drop |
| Last Output | The highest output terminal value that has a wire installed in it. Terminal outputs have a range from 1-22 and are found near the bottom of the timer board. |
| Time Off | 10 |
| Time On | 100 |
| High Limit | 1.00" above initial pressure drop (Contact Manufacturer for Questions) |
| Low Limit | Starting value of 1" below high limit value |
| High Alarm | 10 (Unless alarm is installed - Consult Manufacturing) |
| Low Alarm | 0 (Unless alarm is installed - Consult Manufacturing) |
| Cycle Delay | 0 |
| Down Time Cycles | 10 |
| Auto Alarm Reset | Unless notified, leave at factory setting of 5. |

Start-Up Checklist

- Dust collector completely assembled
- Bolts tightened per specifications on page 6 of this manual
- Fan mounted to the collector after the collector is anchored properly
- Confirm the fan direction matches the rotation arrow on the fan.
- Wiring run to the fan motor from the starter
- Power run to the solenoid enclosure for each solenoid from the timer board outputs
- All wires secured tightly in their terminals per the diagram at the back of this manual
- Compressed air connected to the air manifold
- Compressed air regulator installed and set for 90-95 PSI
- ¼" air tubing connected from the timer board/control panel to the two fittings on the side of the unit
- Timer board programmed per the recommended settings on page 14

Once that is confirmed it is important to check any other accessories that may have been purchased with the unit that require wiring, this includes:

- Remote Start
- Explosion Isolation Valve
- Airlock Starter
- Fire Suppression
- Solenoid Heaters
- Abort Gate
- Broken Bag Detector
- Screw Conveyor
- Explosion Vent Burst Detector

Before turning the collector on make sure:

- Dampers are open on your duct work
- Compressed air is turned on to the unit and confirm there are no air leaks
- All filters are in place and filter doors closed
- Drum lid is attached with a drum under it

Maintenance

Cartridge Filter Replacement

1. Turn off the fan and wait until the down time cleaning cycle is completed.
2. Lock out/ tag out power to the collector and fan.
3. Open the filter access door by pulling and lifting the cam handle.
4. Once door is loose, lift it off the securing hooks and set it down.
5. Reach into the collector and pull out all of the filters. (Or work your way top down to avoid dust from the upper filters falling down on to the new filters).
6. Once filters are removed, install new filters. Make sure that the gasket end goes into the collector first.
7. Reinstall the filter access door.

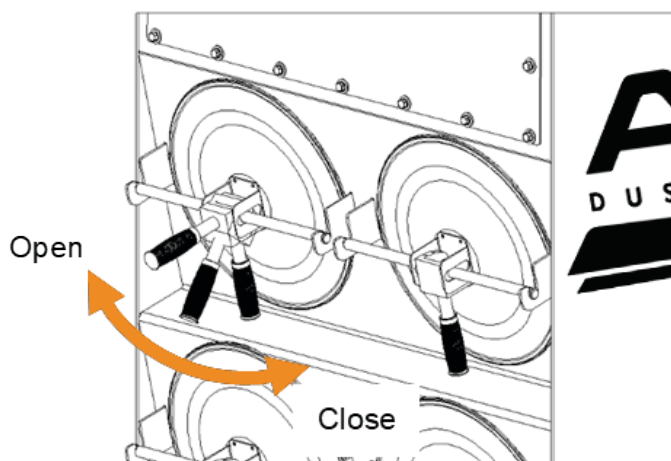

Filter Access Door
(Opening and Closing)

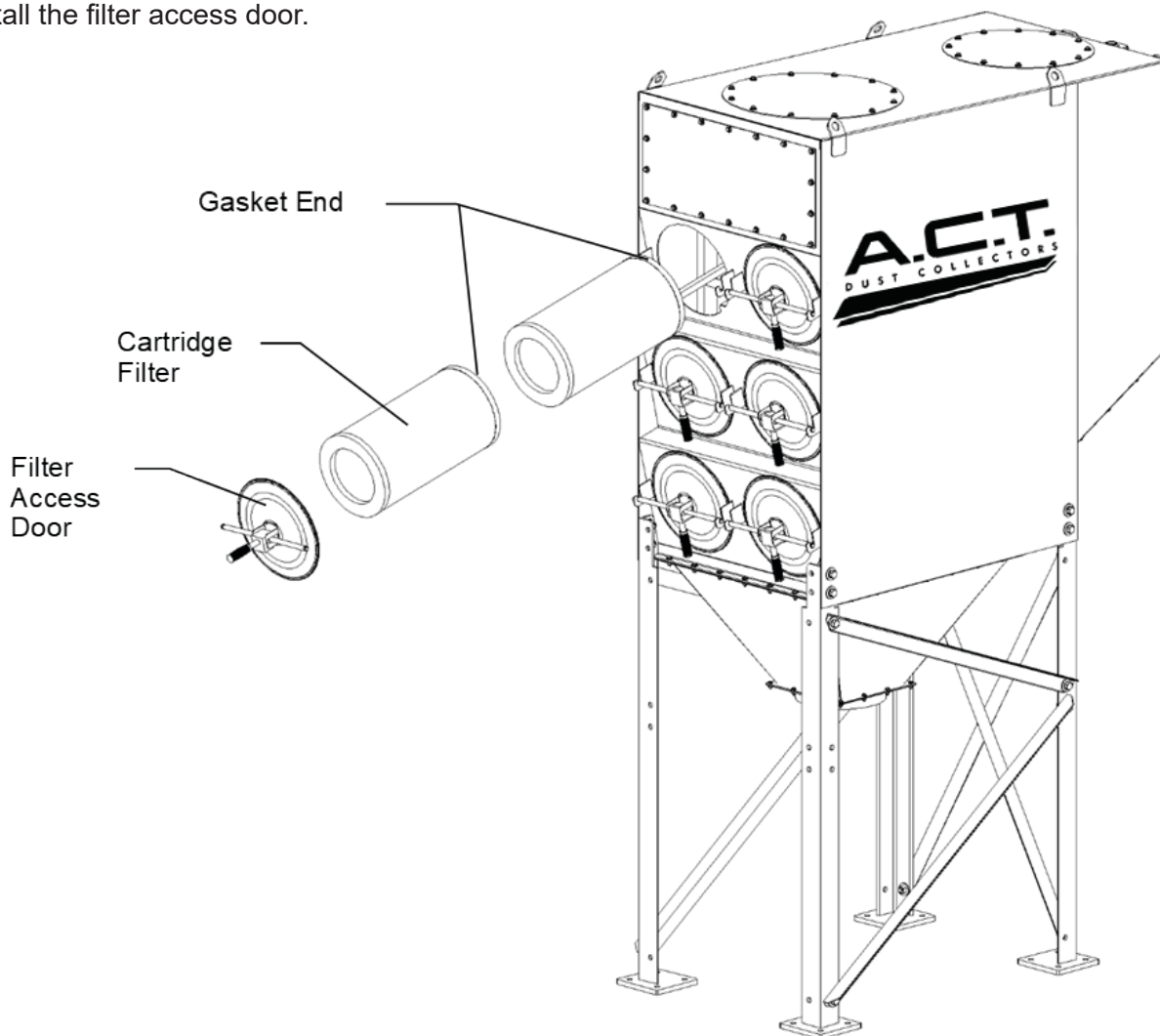

Dust Drawers

Dust Drawers are used as an alternative to hopper and barrel collection methods. Dust is directed into the drawers by baffles inside the collector. It is recommended to check drawers at 1 week intervals initially to determine your dust loading, and adjust from there.

1. Remove bolts or knobs holding drawers in place.
2. Pull out drawer and dispose of contents, making sure to follow any local regulations for material waste.
3. Replace drawers and replace bolts or knobs.

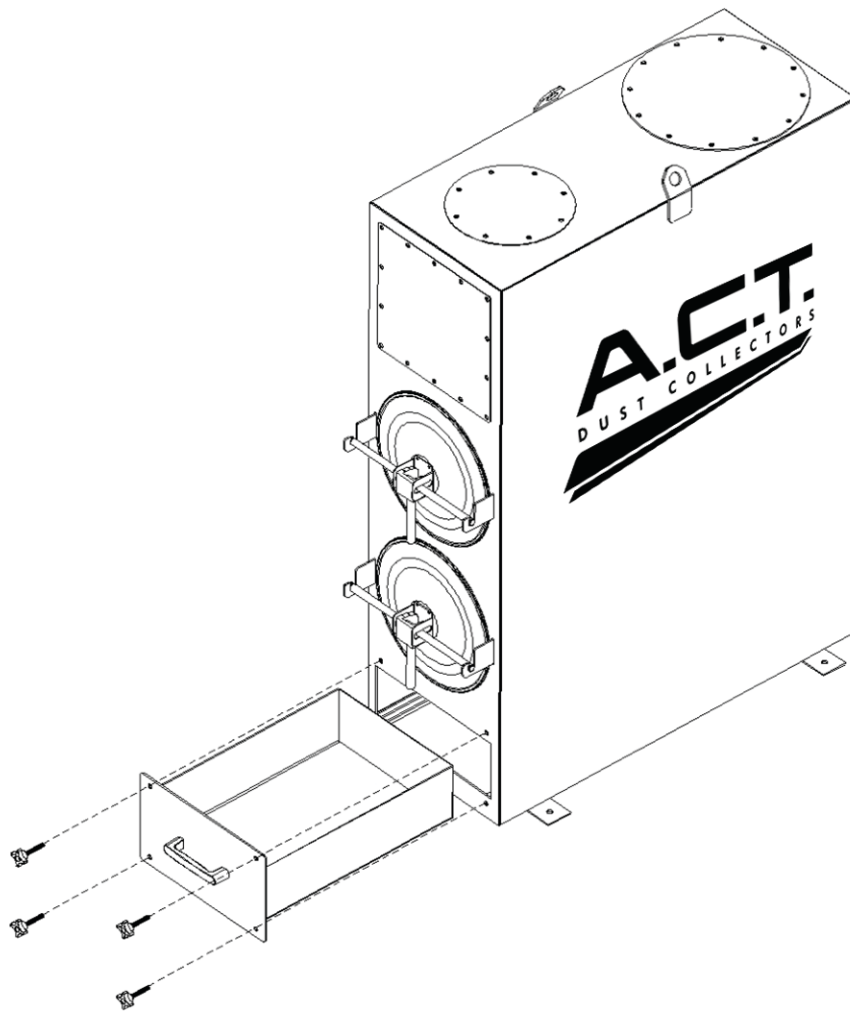

Critical Parts List

Critical Spare parts are always in stock.

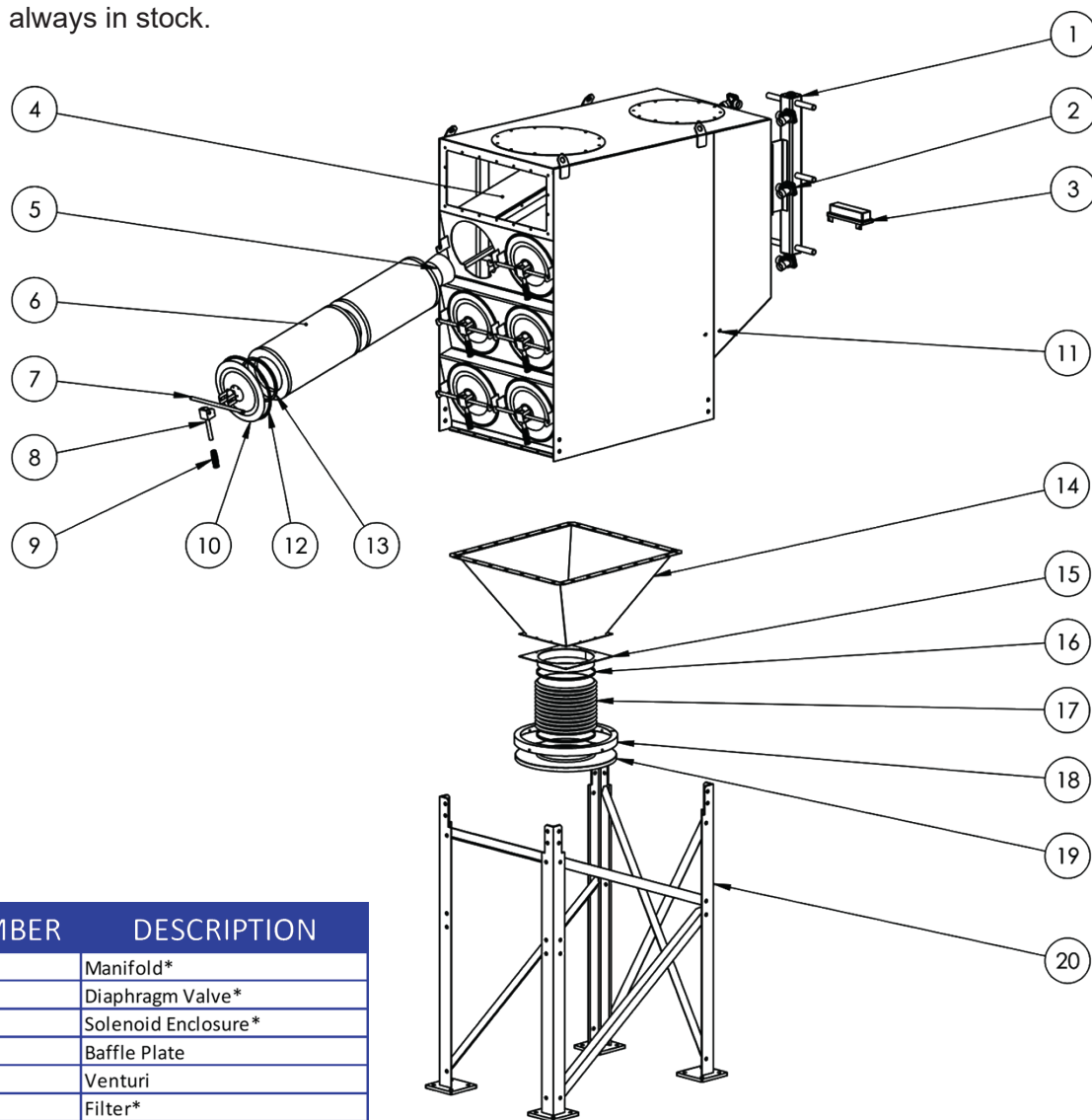

| ITEM | PART NUMBER | DESCRIPTION |
|------|-------------------------|-----------------------------|
| 1 | Various | Manifold* |
| 2 | Various | Diaphragm Valve* |
| 3 | Various | Solenoid Enclosure* |
| 4 | No Part Number | Baffle Plate |
| 5 | DC71000 | Venturi |
| 6 | Various | Filter* |
| 7 | DC13002 | Door Rod |
| 8 | DC79500 | Door Handle |
| 9 | DC76001 | Rubber Grip |
| 10 | DC13001 | Filter Access Door |
| 11 | DC74000 | 90 Degree Elbow |
| 12 | DC79750 | Door Outer Gasket |
| 13 | DC45003 | Door Filter Gasket |
| 14 | DC15002 | Hopper - Standard Size |
| 15 | DC15004 | 14" Hopper Flange |
| 16 | DC76000 | Hose Clamp |
| 17 | DC77500 | 14" Flex Hose |
| 18 | DCA51000 | Latch Ring Kit |
| 19 | DCA12001 | Drum Lid Assembly |
| 20 | Various (1 Leg DC16010) | Leg Pack* |
| | DCA12000 | Filter Access Door Assembly |
| | DC30000 | Timerboard - 6 pin |
| | DC30001 | Timerboard - 10 pin |
| | DC30002 | Timerboard - 22pin |
| | DCA10000 | Standard Hopper/Collar Assy |
| | DCA11000 | Standard Leg Assembly |

*Sizes Vary - Consult Factory

Additional Options (Sold Separately):

These are optional items that can be purchased with an A.C.T. Dust Collector, depending on the dust collector purchased, size and shape may vary slightly.

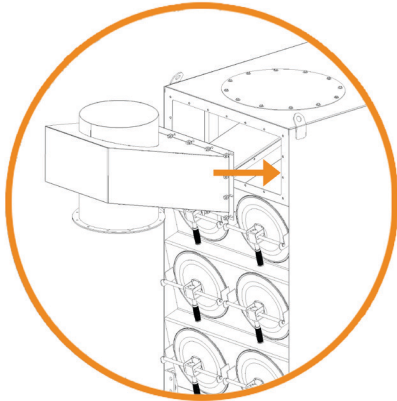

Abrasive Inlet

This is an **optional** item that can be purchased with an A.C.T. Dust Collector, depending on the dust collector purchased, size and shape may vary slightly.

For install remove the front plate (Save the bolt assemblies as they will be reused) on the dust collector and put it into storage. Then install the Sealant Tacky Tape around the rectangle opening on the front of the unit.

Next remove the abrasive inlet from the pallet and lift it into place. Using the original bolts provided fasten the inlet to the front of the dust collector per the photo above.

Access Platform

This is an **optional** item that can be purchased with an A.C.T. Dust Collector, depending on the dust collector purchased, size and shape may vary slightly.

For install, unpackage the access platform and spread out the different pieces.

Lift the main platform into place and secure it to the dust collector using the angle support steel and the hardware kit provided for install.

Next, install the railings using the hardware supplied. Reference drawing above for guidance.

Once the railings are in place and secured tightly, the ladder portion should be bolted to the main platform and then anchored to the ground.

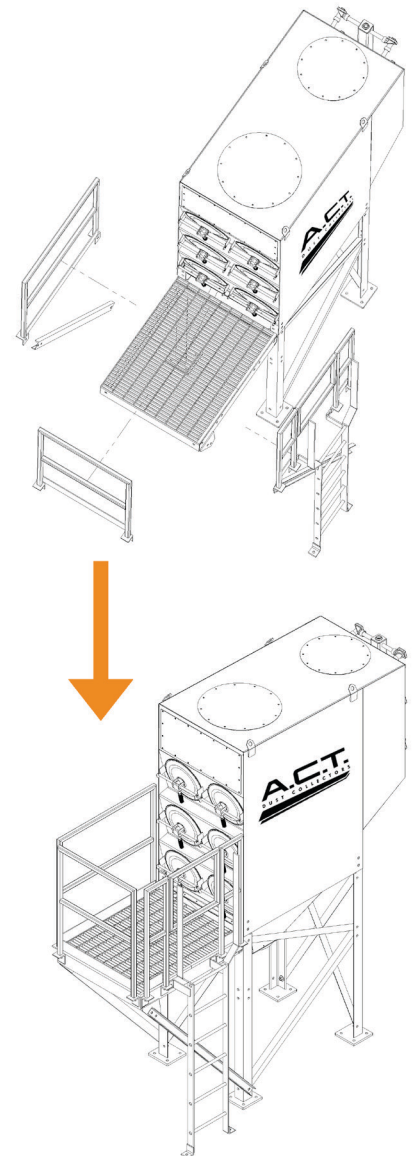

Additional Options (Sold Separately):

These are optional items that can be purchased with an A.C.T. Dust Collector, depending on the dust collector purchased, size and shape may vary slightly.

Bag-In Bag-Out Collars

Bag-in/bag-out collars are used when harmful dusts are present or simply to minimize exposure to any dust. They minimize the amount of dust the operator comes in contact with by allowing the operator to replace the filters by using a bag strapped onto the collar. Although this procedure does greatly reduce exposure to the dusts, it is hard to completely avoid any exposure. It is strongly recommended that the operator still use proper protective clothing, including respirators.

1. Remove the filter access cover and set it aside. If you would like, you can use a bag for this process to further minimize exposure. Starting at the top row of the dust collector will prevent dusts from falling on to new filters already installed in the rows below.

2. Take a new bag and place it over the outside of the bag collar. Secure the bag around the collar with the provided strap. Securely tighten the strap.

3. Grab the bottom of the bag, reach in and twist the filter to drop off any dust that may be in the pleats of the filter, and then pull the filter out into the bag.

4. Before removing the bag from the collar, it is recommended that you twist the bag to prevent the dust from escaping and use a tie to seal off the bag.

5. Remove the bag from the collar.

6. If there are two filters in your filter access hole, repeat this process for the next filter.

7. Place the new filter into the filter access hole. To further minimize exposure to dusts, this can be done by first loading the new filter into a bag.

8. Replace the filter access door and continue this process until all filters have been replaced.

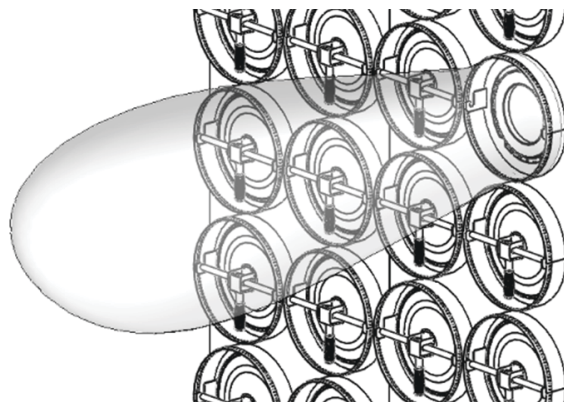

Secure bag on to the collar



Reach in and grab the filter with the bag

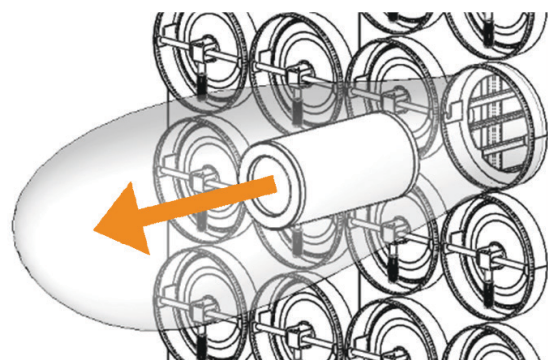

Remove the filter while still inside of the bag

Additional Options (Sold Separately):

These are optional items that can be purchased with an A.C.T. Dust Collector, depending on the dust collector purchased, size and shape may vary slightly.

Airlock

Locate the airlock and remove it from its packaging.

Locate the hardware provided for bolting the airlock to the hopper of the dust collector, this is provided in the hardware kit. Put the sealant tape provided in a ring around the top flange of the airlock, this will be pressed in between the hopper flange and the airlock for a tight leak resistant seal.

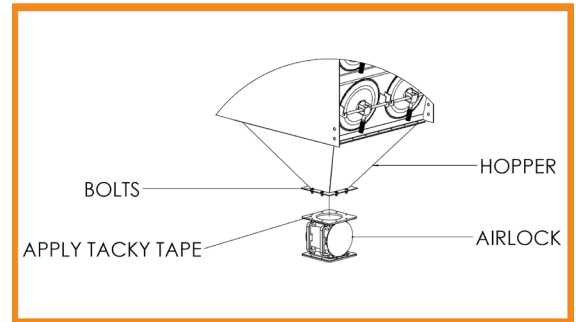

Then lift the airlock into place and fasten it to the hopper. Once it is installed the electrician will need to reference the wiring diagram for how to tie it into the control panel/airlock starter.

Damper

This is an optional item that can be purchased with an A.C.T. Dust Collector, depending on the dust collector purchased, size and shape may vary slightly.

For Install, locate the damper hardware pack and have it on hand for this process. Lift the damper into place, align the damper with the fan outlet.

Once it is aligned tighten down the hardware and secure the damper to the fan outlet.

Silencer

This is an optional item that can be purchased with an A.C.T. Dust Collector, depending on the dust collector purchased, size and shape may vary slightly.

For install, locate the silencer hardware pack and have it on hand for this process. Next, lift the silencer into place and align the bolt holes to the fan* outlet.

Using the hardware mentioned in the first step fasten the silencer to the fan outlet, tighten all bolts securely.

*Note if there is a damper on the system it will be the exact same steps, it is just you will be bolting the silencer to the damper instead of to the fan.

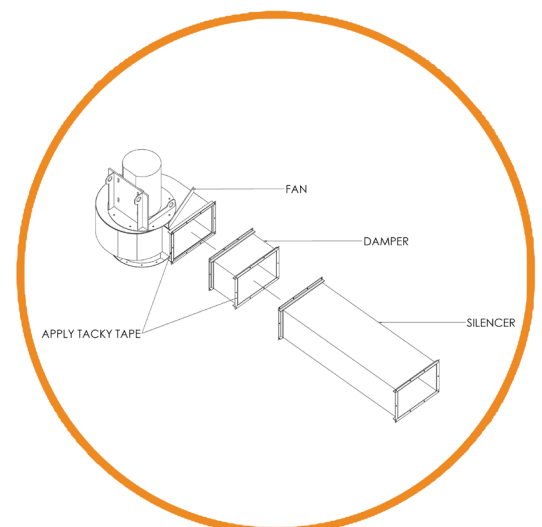

Additional Options (Sold Separately):

These are optional items that can be purchased with an A.C.T. Dust Collector, depending on the dust collector purchased, size and shape may vary slightly.

Solenoid Heater Kit

This is an optional item that can be purchased with an ACT Dust Collector, depending on the dust collector purchased, size and shape may vary slightly.

Confirm whether or not your system was ordered with a solenoid heater kit. If it was, locate the solenoid enclosure on the back of the dust collector. You will need to run (1) Hot and (1) Neutral wire to each solenoid heater (there is 1 heater per enclosure).

Remove the cover from the enclosure, there are (2) Parts to the solenoid heater kit, the thermostat and the element. There are 3 terminals on the top of the thermostat, each terminal is numbered 1-3

Bring your 120V active wire into terminal 3. Tie 1 end of the element into terminal 2. Tie the other side of the element and the neutral wire going to the control panel into terminal 1. Check each wire to be sure they are secured tightly in their terminals.

Reference the diagram on this page.

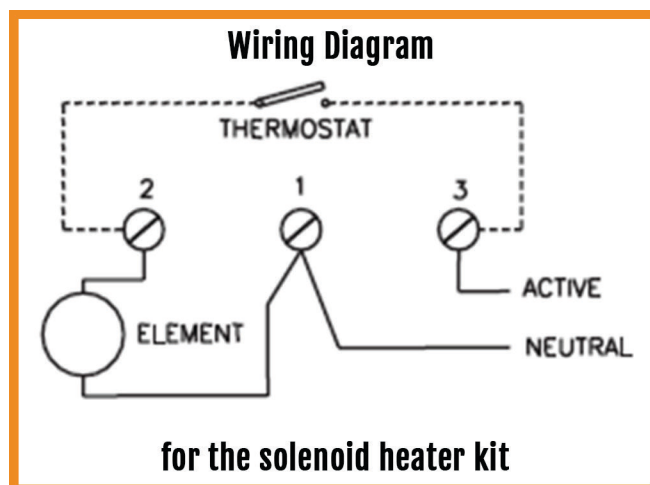

Full Unit Diagram

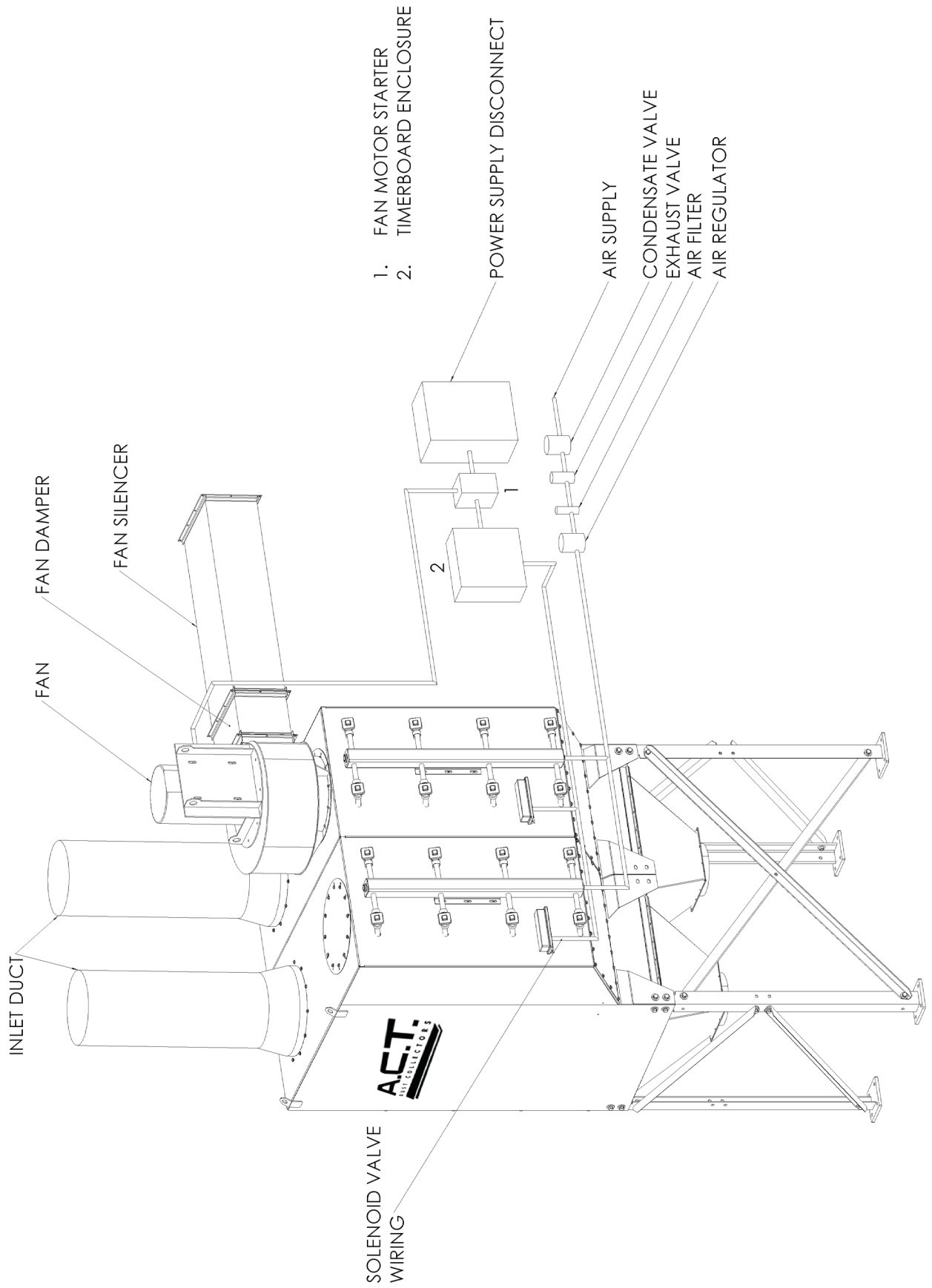

Preventative Maintenance Schedule

| Fan | Item | Period | Description | Procedure |
|-----------|--------------------------|-----------------------|---|--|
| | Lubrication | 3500 Operating Hours | Clean the grease fitting (or area around grease hole, if equipped with slotted grease screws). If motor has a purge plug, remove it. Motors can be regreased while stopped (at less than 80°C) or running. Apply grease gun to fitting (or grease hole). Too much grease or injecting grease too quickly can cause premature bearing failure. Slowly apply the recommended amount of grease, taking 1 minute or so to apply. Operate motor for 20 minutes, then reinstall purge plug if previously removed. | Use 2.12 oz of Polyrex EM grease. |
| | Audio Visual & Vibration | 6 Months | Potentially damaging conditions are often signaled in advance by change in vibration and sound. A simple, regular audio visual inspection of fan operation leads to correction of the condition before expensive damage occurs. Vibration levels should be checked by an approved technician using electronic balancing equipment | Should excessive vibration develop, check the following possibilities: 1. Build-up of dirt or foreign material on the wheel. 2. Loose bolts on motor, fan housings or foundation. 3. The wheel eroding or corroding.. 4. Wheel set screws are loose. 5. Foreign matter may have entered fan causing damage to wheel. 6. Vibration may be coming from a source other than the fan. Stop the fan and determine if the vibration still exists. Disconnect the motor from the fan and operate it by itself to determine if it produces vibration. 7. Proper clearance between the wheel and the inlet. |
| | One-Time checkup | 1 Month After Startup | After approximately one (1) month of operation, all base, hub, motor, etc. bolts should be checked. | Tighten if loose. |
| Collector | Item | Period | Description | Procedure |
| | Diaphragm Valves | 1 Year | De-pressurize manifold. Disassemble diaphragm valve and check rubber element for damage. Check pipe fittings for tightness. Check tube fittings for snugness. | If rubber element is damaged, replace. Call ACT for replacement part. |
| | Pressure Gauge | 1 Month | Check reading of pressure drop across filters. This value will be available through a digital timerboard, or a magnehelic/photohelic gauge. | If pressure drop exceeds and is sustained above 5", replace filters. |
| | 55-Gallon Drum | 2 Weeks | Check dust levels inside the 55 gallon drum(s). | If full or near full, dispose of dust. Follow any local waste regulations. Adjust period as necessary for the system in question (up to 2 months). |

**For Questions and Replacement Parts
Call Toll-Free 800-422-1316**

Troubleshooting

| Problem | Probable Cause | Solution |
|---|--|---|
| Poor performance - not enough suction or air movement | Fan rotation in wrong direction | Rewire three phase wires to change fan rotation |
| | Closed damper or obstruction in airstream | Slowly open damper or remove obstruction |
| | VFD | Verify settings and operating speed |
| | System design | Verify fan performance to fan curve with airflow, static pressure, and amperage readings |
| | | Re-evaluate system design to verify that the fan is properly sized for the application or nothing has changed since product selection (i.e. added a new weld station) |
| | System effects | Check along the duct system to ensure that there is no abrupt changes in airflow (i.e. inlet box with no turning vanes, mitered elbow with no vanes, etc.) |
| | Filters at end of life | Replace filters |
| Not enough compressed air | Verify that the pressure is high enough for effective cleaning (set to 90-100 psi) | |
| High differential pressure | Dirty filters | Activate cleaning by reducing the "high limit" or manually pulse by following the instructions in timer board manual |
| | | Replace filters near end of life |
| | Not enough compressed air | Verify that the pressure is high enough for effective cleaning (set to 90-100 psi) |
| | Defective cleaning system | Verify solenoids, diaphragm valves, and timer board are functioning and properly wired |
| Motor over-amping | Fan design | Overloading radial-bladed fans may require a damper to reduce the horsepower requirements |
| | Electrical | Verify correct motor supply voltage |
| | Fan/motor sized incorrectly | Confirm system requirements with airflow measurements |
| | | Replace fan with larger unit |

Troubleshooting

| Problem | Cause | Solution |
|------------------------------------|--|---|
| Zero differential pressure reading | Wrong pressure high/low pressure tubing connection | Swap the connections of the pressure reading plastic tubing on the side of the collector |
| | Pressure reading tubing kink or leakage | Inspect tubing for kinks or leakage |
| | Filters/Bypass | Verify filters are installed and that there is no bypass of dust |
| | Defective timer board | Replace board. (1-800-422-1316) |
| Cleaning system not pulsing | Solenoid | Listen for clicking noise to verify solenoids are opening/closing. Replace if defective. |
| | | If located in frigid outdoors temperatures, a solenoid heater may be required |
| | Diaphragm Valve | Replace worn diaphragms. (1-800-422-1316) |
| | Timer board | Manually pulse by following instructions in timer board manual. Verify it is correctly installed. |
| | | Defective. Replace board. (1-800-422-1316) |
| No down-time cleaning | Timer board | Verify settings on timer board |
| | Electrical | Call A.C.T. to verify electrical drawings and specifications. (1-800-422-1316) |
| Dust discharging from outlet | Filter damage | Inspect filters for tears along filter media and gaskets. |
| | Filters installed incorrectly | Verify that the filters are installed correctly with gasket end towards the collector. |
| | Pulse pressure set too high | Decrease compressed air pressure. |

Warranty

Air Cleaning Technology, Inc. (A.C.T. Dust Collectors) warrants the equipment to be free from defects in materials and workmanship for a period of 10 years from the date of purchase. This warranty does not cover any damage due to normal wear and tear including, but not limited to, corrosion, abrasion, elements, and modifications. This warranty covers parts only. This warranty covers only the parts manufactured exclusively for Air Cleaning Technology, Inc. All other parts will be covered by individual manufacturer's warranty.

ATTENTION DISCLAIMER

For stainless steel dust collector installation, there is a possibility of thread galling on the supplied fasteners. To avoid this occurrence as best as possible, please follow the steps outlined below.

1. Slowing down the installation RPM speed will frequently reduce, or sometimes solve completely, the problem. As the installation RPM increases, the heat generated during tightening increases. As the heat increases, so does the tendency for the occurrence of thread galling.
2. Lubricating the internal and/or external threads frequently eliminates thread galling. The suggested lubricants should contain substantial amounts of molybdenum disulfide (moly), graphite, mica, or talc. Some proprietary, extreme pressure waxes may also be effective. You must be aware of the end use of the fasteners before settling on a lubricant. Stainless steel is frequently used in food related applications, which may make some lubricants unacceptable. Lubricants can be applied at the point of assembly or pre-applied as a batch process similar to plating. Several chemical companies offer anti-galling lubricants. One such source, EM Corporation, suggests their Permaslik™ RAC product for use at the point of assembly. They suggest Everlube™ 620C for batch, pre-applying to stainless steel fasteners.



820 North Front Street
New Ulm, MN 56073
763-557-7162
info@actdustcollectors.com



Series DCT1000 Dust Collector Timer Controller

Specifications – Installation and Operating Instructions

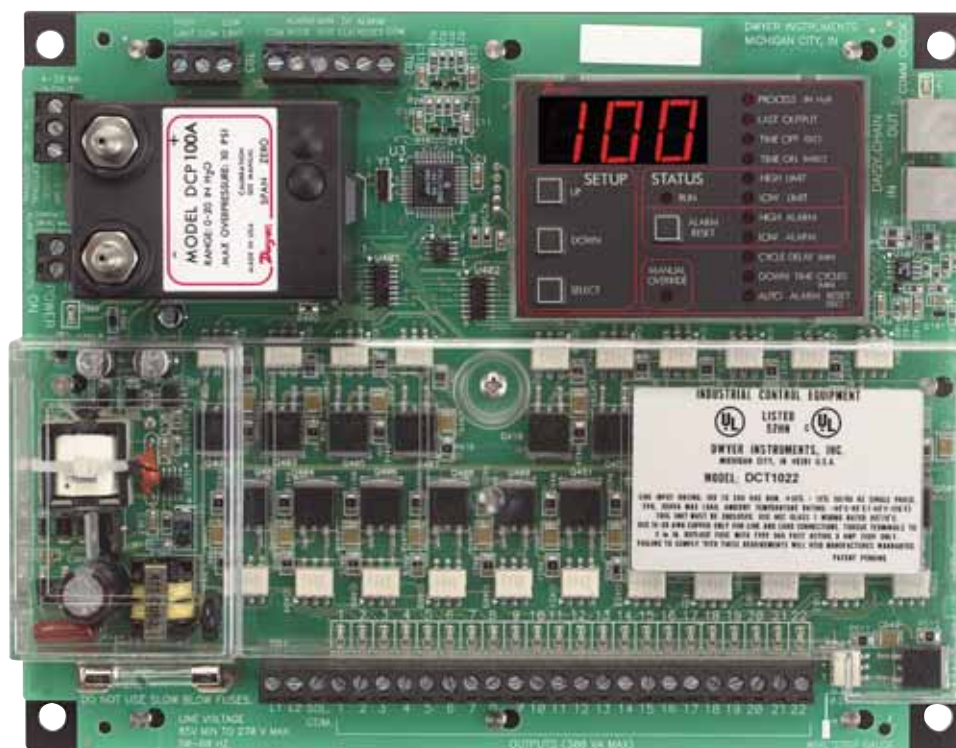

Thank you for purchasing the DCT1000 Dust Collector Timer Controller. You have selected a state of the art dust collector timer control that will provide years of dependable operation and service.

The DCT1000 Dust Collector Timer Controller was designed to be used with pulse-jet type dust collectors for on-demand or continuous cleaning applications.

Continuous cleaning applications do not require external inputs and can be used for time based "on-demand" cleaning through use of the cycle delay feature.

For on-demand applications, the plug-in pressure modules (DCP100A/200A) can be used to take full advantage of all the features the DCT1000 offers, or an external pressure switch (such as the Dwyer Photohelic®) can be used for High/Low limit control.

As with traditional Dwyer products, the Dwyer DCT1000 was designed so that it is easy to use, thus allowing for a quick and easy start up for your dust control applications. The contents inside this installation and operating manual will guide you through the features of the DCT1000 and how they can be applied to get the most out of your dust control requirements.

SPECIFICATIONS

DCT1000 Timer Controller:

Output Channels: 6, 10, & 22 channels. Expandable to 255 channels using DCT1122 & DCT1110 channel expander boards.

Power Requirements: 85 to 270 VAC, 50 or 60 Hz.

Solenoid Supply: 3A maximum per channel.

Fuse: 3A @ 250 VAC. Low voltage control circuitry is isolated from the line voltage for system safety.

Temperature Limits: -40 to 140°F (-40 to 60°C).

Storage Temperature Limits: -40 to 176°F (-40 to 80°C).

On Time: 10 msec to 600 msec, 10 msec steps.

On Time Accuracy: ±10 msec.

Off Time: 1 second to 255 seconds, 1 second steps.

Off Time Accuracy: ±1% of the value or ±50 msec, whichever is greater.

Weight: 1 lb 3.0 oz (538.6 g).

Agency Approvals: UL, cUL.

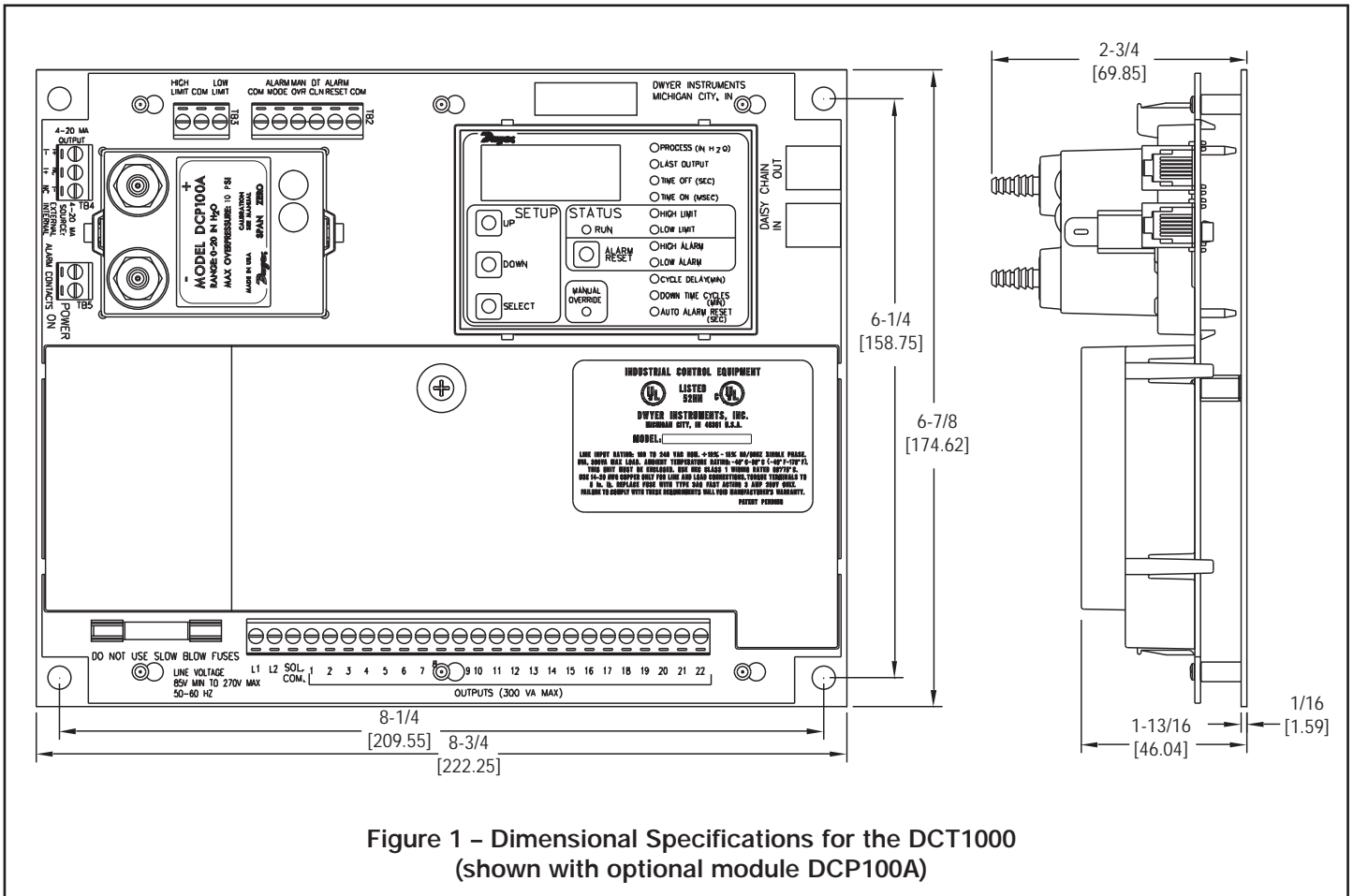
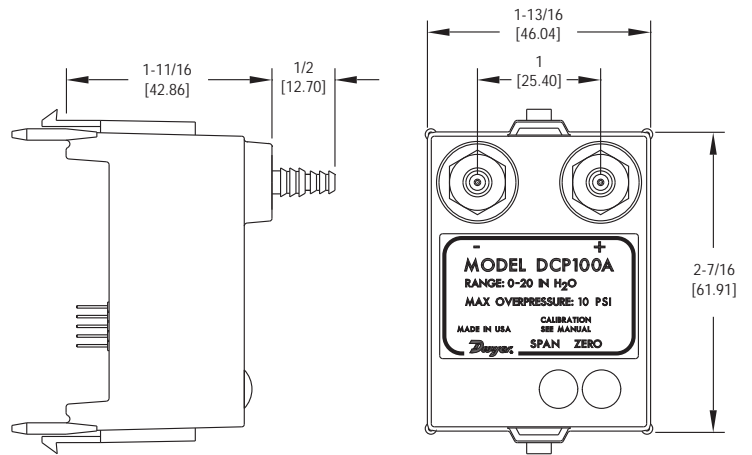

Figure 1 – Dimensional Specifications for the DCT1000 (shown with optional module DCP100A)



The DCP100A or DCP200A pressure modules are designed exclusively for use with the Dwyer DCT1000 Dust Collector Timer Controller boards for on-demand cleaning requirements. These series of modules are available in 10" w.c. [2.49 kPa] or 20" w.c. [4.98 kPa] ranges, which allow for differential process pressure measurement as indicated on the display of the master controller. An isolated 4-20 mA readout channel is provided for remote pressure display. The 4-20 mA output may be wired either for use with an external power supply and indicator or using the isolated on-board 24 volt power supply to power the loop.

SPECIFICATIONS

Pressure Ranges: 10" w.c. or 20" w.c.

Temperature Limits: -40 to 140°F (-40 to 60°C)

Pressure Limit: 10 psi (68.95 kPa).

Pressure Limit (differential): 10 psi (68.95 kPa).

Accuracy: ±1.5% F.S. @ 73°F (22.8°C).

Output Signal: 4-20 mA.

Alarm Contacts: 1.5A inductive load, 3A resistive load @ 30 VAC or 40 VDC.

Process Connections: Two barbed connections for use with 1/8" (3.18 mm) or 3/16" (4.76 mm) I.D. tubing.

Weight: 5.5 oz (155.9 g).

| Table of Contents | Page No. |
|--|----------|
| Figure 1 Dimensional Specifications | 2 |
| 1.0 Installing the DCT1000 | 3 |
| 1.1 Power Requirements | 3 |
| 1.2 DCT1000 Terminal Connections | 3 |
| 1.2.1 External Pressure Connection | 3 |
| 1.2.2 Manual Override Switch Connection | 4 |
| 1.2.3 Down Time Clean Connection | 4 |
| 1.2.4 Connecting Multiple Timer Boards | 4 |
| 1.2.5 Continuous Cycle Mode | 4 |
| Figure 2 Wiring Connections | 4 |
| 1.3 DCP Installation | 5 |
| Figure 3 DCP Installation | 5 |
| 1.3.1 Location | 5 |
| 1.3.2 Connecting DCP to Master Controller | 5 |
| 1.3.3 Pressure Model Locking Pins | 5 |
| 1.3.4 DCP Connections | 5 |
| 1.3.5 DCP Maintenance | 5 |
| 1.4 Alarm Mode Switch Connection | 5 |
| 1.4.1 Alarm Reset Switch Connection | 5 |
| 1.4.2 Connecting the 4-20 mA Loop | 5 |
| 1.4.3 Connecting the Alarm Relay | 6 |
| 1.5 Three Position Selection Switch Wiring | 6 |
| 2.0 Programming the DCT1000 Master Controller | 6 |
| 2.1 Last Output Setup | 6 |
| 2.2 Time Off Setup | 6 |
| 2.3 Time On Setup | 6 |
| 2.4 High Limit Setup | 7 |
| 2.5 Low Limit Setup | 7 |
| 2.6 High Alarm Setup | 7 |
| 2.7 Low Alarm Setup | 7 |
| 2.8 Cycle Delay Setup | 7 |
| 2.9 Down Time Cycles Setup | 7 |
| 2.10 Auto Alarm Reset Setup | 7 |
| 3.0 Maintenance Support and Diagnostics | 7 |
| 3.1 Restoring Factory Defaults | 7 |
| 3.2 Power Indicator | 7 |
| 3.3 Active Channel Indicator | 7 |
| 3.4 Comm Check Indicator | 7 |
| 3.5 Error Codes | 8 |
| 4.0 Glossary of Terms | 8 |
| Customer Service Phone Number | 8 |



Caution: Do not run control wires, communication cables, or other class 2 wiring in the same conduit as power leads. The system may malfunction if class 2 wiring is run together with power conductors.

1.1 Power Requirements

The controller has a “universal” power supply that will allow operation on 120 VAC to 240 VAC power lines. The input voltage must be between 85 VAC and 270VAC either 50 or 60 Hz. No circuit changes are required when switching between these voltages. The solenoid loads, however, must be sized to accommodate the line voltage selected.

1.2 DCT1000 Terminal Connections

The line and solenoid connections are located at the lower edge of the board below the plastic guard. The terminal block is a “Euro” style connector system that clamps the wire within the connector body. The connector will accept wire sizes from 14 to 22 AWG. The wire should be stripped to no more than 0.25 inches to avoid shorts or expose line voltages creating a potential safety hazard. To assist you in determining the proper wire gauge required, a strip gauge is provided at the lower right corner of the board. The connector system used on the DCT1000 is specified for single connection but you can piggyback to a single lug provided that local codes allow for this and good workmanship practices are followed. To power up the master controller and the channel expander, connect line power to L1 and L2 (see Dimensional Specifications, Figure 1). Connect the solenoids between the selected output and the solenoid common. Solenoid common and L2 are internally connected. Switches connected to the control inputs at the top of the board must be isolated contacts connected only to the relevant terminal and to the common terminals. The following subparagraphs describe the external switch connections. Refer to figure 2 for switch connection illustration.

1.2.1 External Pressure Connection

The controller may be used with an external pressure limit switch or sensor to provide demand-cleaning operation. The high limit and low limit inputs may be used for this purpose. A simple on-off system can be established with a single pressure switch connected to the high limit input. Better control can be achieved with a high and low limit switch/gage such as the Dwyer Photohelic®. In this on-demand mode, time on, time off, and cycle delay may be programmed to define the cleaning cycle. A three pin terminal block (TB3) provides connection for external high and low limit switches (see Figure 2 on the next page). These switches must be isolated contacts. The common line must not be connected to equipment ground or protective ground, since these may introduce electrical noise and cause improper operation or possible damage to the control board. The operation of these inputs are summarized as follows (see next page):

| Current Operation | Low Limit Switch | High Limit Switch | Next Operation |
|----------------------------------|------------------|-------------------|----------------|
| Hold | Open | Open | Hold |
| Hold or Run | X | Closed | Run |
| Hold | ∅ | Open | Hold |
| Hold | Closed | ∅ | Run |
| Run | Closed | ≠ | Run |
| Hold | Closed | ∅ | Run |
| Run | ≠ | Open | Hold |
| ∅ Transition from open to closed | | | |
| ≠ Transition closed to open | | | |
| X Either open or closed | | | |

Note: If a DCP100A or DCP200A pressure module is installed in the master controller, the switching functions are ignored.

1.0 Installing the DCT1000



Warning: Always install and service this device with the power off and a lockout installed if required. Line voltages will be exposed at the power/output connector and at the fuse. For this reason, we have installed a plastic guard to protect the user from accidentally contacting line voltages.

Please note that the power guard serves as a safety feature and should not be removed under any circumstances.

For ease of installation and maintenance, the connectors and fuse have been left unprotected. The open frame design of the DCT1000 will require an enclosure that meets appropriate safety and local code requirements. For optimal performance, the enclosure should also protect the controller from dirt, water and direct sunlight. There are no special orientation requirements, and the controller mounts easily using the mounting holes on the factory installed base plate.

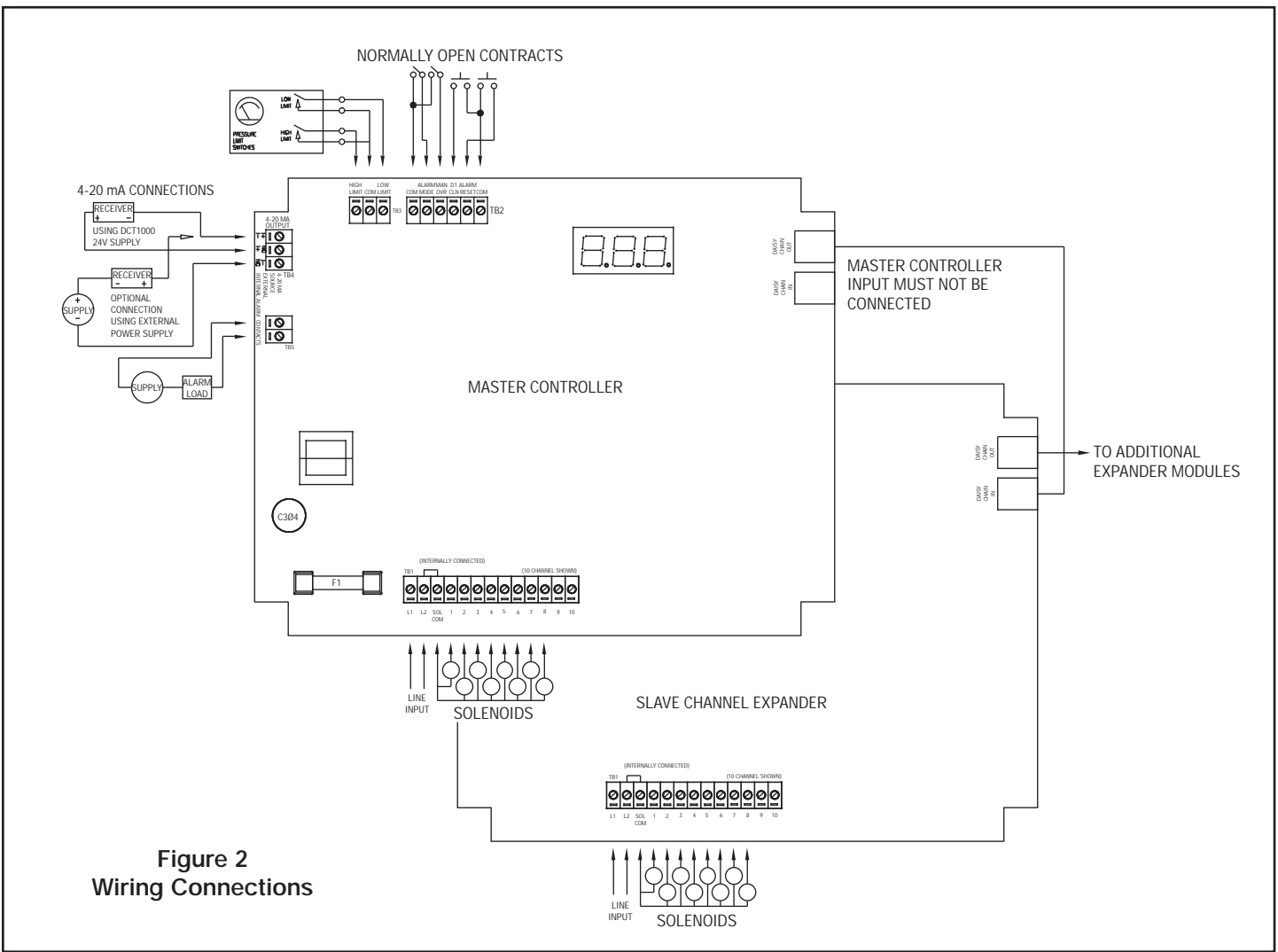

Figure 2
Wiring Connections

1.2.2 Manual Override Switch Connection

The manual override function allows the system to be set to the run mode regardless of other conditions. This mode is enabled when the manual override terminal and common are connected. It is disabled when they are disconnected. If the controller is to be run in continuous mode, a jumper wire may be wired across these terminals. When manual override is needed on a periodic basis, wire a SPST toggle switch between the manual override terminal and the common terminal.

1.2.3 Down Time Clean Connection

The down time clean operation forces the system into a run cycle for a programmed length of time between 0 – 255 minutes. The operation is initiated by connecting the down time clean terminal to a common terminal. This function is best accomplished through use of an external normally open switch.

1.2.4 Connecting Multiple Timer Boards

Both master controller boards and slave boards can have up to a maximum of 22 channels each. The system may be expanded up to 255 channels using master controller boards and slave boards. The DCT1000 will automatically detect the total number of channels involved and make their outputs available. You will note that both the master controllers and slave boards have a telephone style connector mounted on the upper right hand side of the board. These connectors are for use in systems requiring slave boards that must be daisy chained together to provide additional channel capability. For systems that require the slave boards, the master controller must not have any connection made to its daisy chain input unless it is designated as a slave control itself. (For larger systems requir-

ing more than three slave boards, a master controller must be used as the fourth slave board to satisfy power requirements.) This sequence would repeat itself until the limit of 255 channels has been reached. The cables used are not ordinary telephone style cables.



Caution: Do not use telephone jumper cables. These have a “twist” in the connection and may damage the controllers. Cables designed for use with the DCT1000 are available from Dwyer Instruments (Model DCAC02-2 ft., DCAC04-4 ft., etc.).

1.2.5 Continuous Cycle Mode

The master controller has several operating modes available for different applications. Starting with the most basic mode, it is capable of operating in a continuous cleaning cycle. This can be initiated by either placing a jumper between the high limit input and the common, or the manual override input to the common connection. Controlling this cycle are three setup parameters: time off, time on, and cycle delay. Time on and time off specifically deal with the solenoid on time and the time interval between the end of the on pulse and the start of the next. The cycle delay allows a delay of up to 255 minutes to be programmed between the end of one complete cleaning cycle and the beginning of the next. This allows additional options for defining a cleaning profile.

1.3 DCP Installation



Caution: Prior to installing the DCP100A/200A please review the operating specifications carefully.

Some operating systems, especially in pneumatic conveying applications, may see static pressure or vacuum conditions that exceed the capability of the DCP100A/200A pressure module. For these conditions there are a number of alternate Dwyer pressure products that can be used to meet your application requirements, all of which can be terminated to the Dwyer DCT1000 Dust Collector Timer Controller. For more information on these and other Dwyer products, please call us at (219) 879-8000, or visit us on the web at www.dwyer-inst.com or www.dust-controls.com.

1.3.1 Location

The system should be located in an enclosure that meets relevant safety standards and electrical codes. There are no other special orientation requirements as the pressure module is not orientation sensitive. Care should be observed when routing the air hoses to ensure that any potential condensation or moisture will not drain into the sensor. Where heavy condensation is present, a drip loop or an in-line filter should be installed to ensure long term operation.

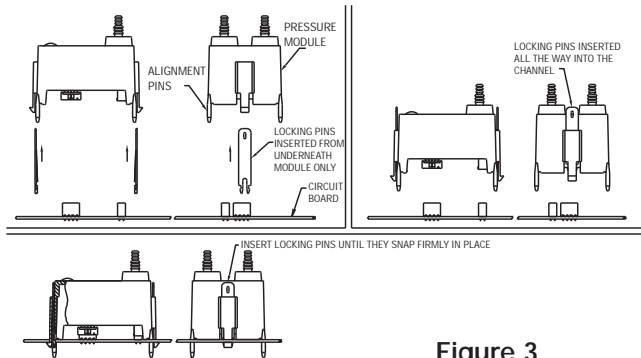

Figure 3
DCP Installation

1.3.2 Connecting DCP to Master Controller

The pressure module is attached to the Master Controller using integral connectors on both units. The insertion ports for the pressure module are located in the upper left quadrant of the DCT1000 Master Controller. The pressure module can be removed by compressing the retaining clips on each end of the module, then gently pulling the module out of the master controller board.

When inserting the module, the following procedure should be adhered to insure proper installation:

- Examine the bottom of the pressure module and note the orientation of the connectors.
- Align the module so that these connectors match the connector receptacles on the controller board.
- Orient the module with the four alignment pins over their respective mounting holes.
- Gently press the module into the connectors and snap the retaining clips on either end of the module into their slots.
- Always install and service this device with the power off and a lockout installed if required. "Hot" plugging the pressure module into an operating system may damage the system or cause the calibration parameters to be erased.

When installing or removing the module make sure to orient the module straight with board. Installing or removing the module at any angle may break the alignment pins.

1.3.3 Pressure Model Locking Pins

The DCP100A and DCP200A are supplied with locking pins to secure the module. In normal operation these are not required since the latching tabs are sufficient to secure the module even in a high vibration environment. However if the unit is to be shipped or used where severe mechanical shock could be encountered the locking pins ensure the module will not snap out of the board.

To install the locking pins, from underneath the module insert one pin behind each of the two latching tabs. Press these all the way into the channel. The ends of the tabs will extend through the slots at the top of these channels. Next insert the module in the board as described above, making sure it is properly aligned and snaps firmly in place. Press the exposed locking tabs down until the tab is seated behind the latch in the board. To remove the module, slide the locking tabs up using a small screw driver then remove the module as described above. See Figure 3.

1.3.4 DCP Connections

When a pressure module is installed, the 4-20 mA process signal and the alarm relay contacts are available. The 4-20 mA circuit is isolated from ground and other signals. The alarm relay contacts are isolated, normally open contacts. Pressure connections may be made to the stepped hose barbs with either 1/8" or 3/16" I.D. tubing.



Caution: Do not force the module into the connectors. Forcing the insertion may damage the connectors. Properly aligned, the module should snap into place.

1.3.5 DCP Maintenance

The pressure module should require very little maintenance under normal operational conditions. However, periodic calibration may be desirable to assure accuracy of the readings. The module may be removed and returned to the factory for calibration.

1.4 Alarm Mode Switch Connection

The auto alarm reset is controlled by the alarm mode switch connection. To enable the auto alarm reset the alarm mode input must be connected to a common connection. A jumper may be used when auto alarm reset is always active. A switch may be used if there are times that the auto alarm reset must be disabled. The switch must be an isolated contact and wired such that no connection is made between either of the wires and ground. See Figure 2 Wiring Connections.

1.4.1 Alarm Reset Switch Connection

The alarm may be reset either by pressing the Alarm Reset button on the control panel or by an external switch connected between the alarm-reset terminal and one of the common terminals. The alarm reset will only operate if the pressure module is installed and the pressure has returned to a normal condition. See Figure 2 Wiring Connections.

1.4.2 Connecting the 4-20 mA Loop

The pressure module provides an isolated 4-20 mA output, which may be used to remotely monitor the differential pressure across the dust bags or cartridges. The connection is made on the master control module at the terminal block designated for this signal. The connection is a 2-wire configuration with the option of using either an external 15 to 35 VDC power source or using the internal 24 VDC source. See Figure 2 Wiring Connections.

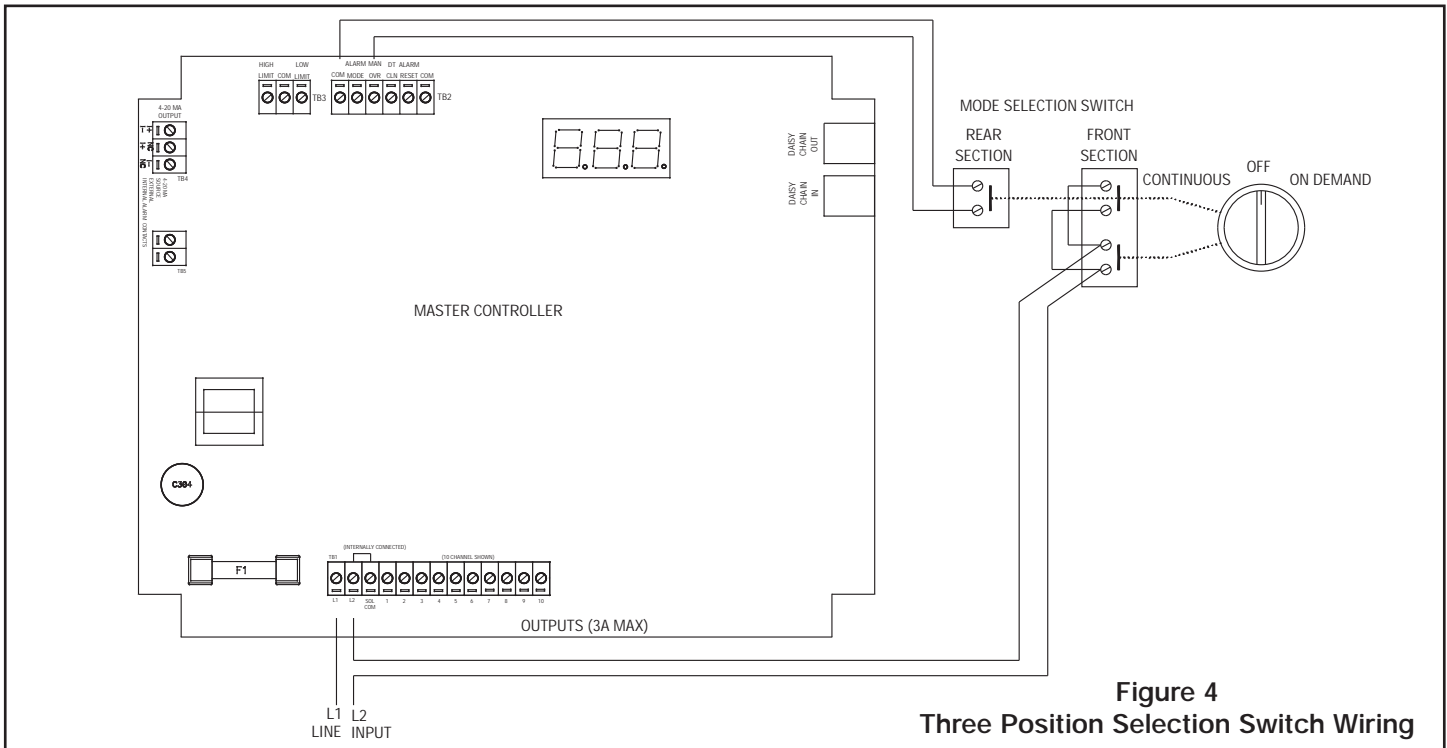

Figure 4
Three Position Selection Switch Wiring

1.4.3 Connecting the Alarm Relay

With the pressure module installed, a relay contact is provided for controlling an external alarm. This relay is a single form-A contact. It is activated when either the high alarm threshold is exceeded, or the pressure drops below the low alarm threshold. The connection is made at the two-pin connector TB5. See Figure 2 Wiring Connections

1.5 Three Position Selection Switch Wiring

An optional mode selection switch is available with the weather-proof enclosure. With this switch the user may select either continuous cleaning, on-demand cleaning, or off. This switch is supplied factory wired as shown in Figure 4. The switch has a front and rear section. The front section, consisting of two independent contacts, controls the power to the board. These contacts must be wired in parallel as shown in the diagram. The rear section controls the manual override, which when closed will force the system into a continuous must be reconnected, follow the wiring diagram.

Caution: Do not interconnect the low voltage manual override leads with the power leads. This will destroy the control board as well as pose a serious shock hazard

2.0 Programming the DCT1000 Master Controller

We've made it easy to navigate the DCT1000. Menu items can be accessed simply by pressing the "SELECT" button. The menu item that you are currently accessing is indicated by the illumination of an LED. To change menu items, all you have to do is push "UP" to increase a value or push "DOWN" to decrease a value. There are no keystrokes that you need to memorize, special combinations, or passwords that are required.

The master controller is equipped with an on board display and programming information center. The controller will power-up with the process indicator illuminated. If a pressure module is installed, the display will indicate the measured pressure in inches of water (w.c.); otherwise it will normally be blank.

2.1 • Last Output

The Last Output setup selects the last channel to be activated. When first selected, the display will flash the last output available in the system. With single board installations, this will be the number of channels installed, typically 6, 10 or 22. This value becomes more important when multiple modules are installed. The last output value flashed will be the sum of all channels available in the system.

After the last available channel indication has completed, the currently programmed last channel value is displayed. This value may be changed using the "UP" and "DOWN" buttons. The minimum value is one while the maximum value is the maximum number of installed channels, including all expansion modules. The default value is the maximum number of channels. Pressing "SELECT" will change the setup mode to Time Off Setup.

2.2 • Time Off (Sec.)

Time off defines the period of time between solenoid activations when no channels are enabled. This may be set between one second and 255 seconds. The factory default is 10 seconds. The display will show the current time off setting when the time off setup mode is entered. The value may be changed using the Up and Down buttons. Pressing both "UP" and "DOWN" simultaneously and holding for approximately four seconds will restore the default value of 10.

2.3 • Time On (msec)

Time On Setup sets the solenoid on time. The display will indicate the currently programmed time on setting. This is measured in milliseconds. Using the "UP" and "DOWN" buttons, the value may be changed. The value may be set between 10 msec and 600 msec in 10 msec increments. Pressing the "UP" and "DOWN" buttons simultaneously for approximately four seconds will restore the factory default value of 100 msec. Pressing the "SELECT" button will advance the setup mode to the High Limit setup if the pressure module is installed. With no pressure module, it will step to Cycle Delay Setup.

2.4 • High Limit [Only available when DCP connected]

The High Limit Setup, available only with a pressure module installed, sets the pressure at which the cleaning cycle will begin. This value may be between zero and the pressure module full scale pressure. Normally, the High Limit should be above the Low Limit. If, however, the High Limit pressure is set below the Low Limit, the cleaning cycle will begin when the High Limit is exceeded and stop when the pressure falls below the High Limit. The Low Limit in this case will have no effect. Pressing "SELECT" will change the system to the Low Limit Setup mode.

2.5 • Low Limit [Only available when DCP installed]

The operation of the Low Limit, available only with a pressure module installed, is identical to the High Limit except this value sets the pressure where the cleaning cycle will end. The upper settable value is the calibration pressure of the pressure module and the lower limit is zero. Pressing "SELECT" will change the system to the High Alarm Setup mode.

2.6 • High Alarm [Only available when DCP installed]

The operation of the High Alarm Setup is identical to the High and Low Limit Setup and is only available when a pressure module is installed. The High Alarm default is 0. The upper settable value is the full scale pressure of the pressure module and the lower limit is zero. Pressing "SELECT" will change the system to the Low Alarm Setup mode.

2.7 • Low Alarm [Only available when DCP installed]

The operation of the Low Alarm Setup is identical to the High and Low Limit Setup. The Low Alarm default is 0. The upper settable value is the full scale pressure of the pressure module and the lower limit is zero. Pressing "SELECT" will change the system to the Cycle Delay Setup mode.

2.8 • Cycle Delay (min)

The cycle delay inserts a delay time between the end of the last channel and the beginning of the first channel. This may be set to between zero and 255 minutes. The factory default is zero. Setting the value to zero will disable the delay. Pressing "SELECT" will change the system to the Down Time Cycles Setup mode.

2.9 • Down Time Cycles (min)

The Down Time Cycles setup will select a value between zero and 255 minutes. The factory default is one minute. Selecting zero will disable the operation. When the down time cycles is activated by shorting the down time cycles input to the common terminal, (see figure 2) the system will enter a forced cleaning mode for the programmed duration. *NOTE:* The cycle delay, if one is programmed, will not be inserted in the timing cycle. Pressing "SELECT" will change the system to the Auto Alarm Reset Setup mode, if a pressure module is installed, or to Process when no pressure module is available.

2.10 • Auto Alarm Reset (sec) [Only available when DCP installed]

The Auto Alarm Reset Setup, available only when a pressure module is installed, allows the auto alarm reset time to be selected. This value may be set between zero and 255 seconds. The factory default value is five seconds. When the auto alarm reset is enabled by shorting the auto alarm reset terminal to a common terminal, (See Figure 1) the alarm will be reset after the pressure returns to the normal range and the timeout has expired. Pressing "SELECT" will change the system to Process mode.

3.0 Maintenance Support and Diagnostics

We have also included a number of features that will aid maintenance personnel in diagnosing problems or verifying that the system is operating.

3.1 Restoring Factory Defaults

The DCT1000 has been programmed with factory default values that meet most industry operating conditions. In the event that you want to restore all of the parameters to the original factory default values:

- (1) Return the master controller to the process mode.
- (2) Press and hold both "UP" and "DOWN" buttons.

The display will indicate a 10-second countdown, at the end of which all parameters will be restored to factory defaults. Releasing the switches prior to the end of the count will stop the process and no modification will be made. Likewise, in each of the parameter setup modes, pressing and holding the "UP" and "DOWN" buttons simultaneously will reset the individual default value, leaving other settings unchanged.

3.2 Power Indicator

A power on LED indicator is provided at the center left edge of the board. This will be illuminated when the power supply is operating properly. If the power LED is not illuminated, the primary power may be off or there is a fault in the power circuit.

3.3 Active Channel Indicator

Located just above the solenoid terminations, you will find that each channel is provided with an LED that is illuminated when the triac switch is on. This allows a visual correlation between the channel being pulsed and the operation of the solenoid.

3.4 Comm Check Indicator

The comm check indicator can be found in the upper right hand corner of the slave and master controller board (just above the "out" terminal, a telephone style connector). This indicator is used for two purposes. First, on a master controller a brief flash once per second is produced to indicate that the system is operating. Second, this indicator is used to show when the communication check operation is performed on slave boards. The master controller will check each of the slave boards at a rate of about one inquiry per second, starting with the slave board connected directly to the master controller and ending with the last slave board in the chain. The master controller will flash its Comm Check LED for about 250 msec each time it makes a communication check. The external module selected for test will also flash its Comm Check LED for about the same time each time it is interrogated. Observing this test sequence will indicate that the communication between boards is operational. When a slave board powers up, the Comm Check LED will be illuminated continuously. It will be extinguished when the master controller has initialized its communication channel. This indicator then shows that a master controller is operating and that each slave board is responding properly on the daisy chain.

3.5 Error Codes

Error codes will be displayed on the three-digit display when certain faults occur. Most of these indicators are associated with the daisy chain communication, but certain error codes pertain to single board operation also. These codes are:

| Display | Meaning | Action Required |
|---------|--|---|
| Err 1 | This is a "watchdog" reset that is enabled when the master controller isn't able to cycle through its operation. | Make sure all electrical connections are appropriately shielded so the master controller is not disrupted by noise. |
| Err 2 | The pressure module has failed to respond to the request of the master controller. | The master controller will try to recover from the fault. If unsuccessful, replace the pressure module. |
| Err 3 | Communication error in the daisy chain interface. This will only appear when the master controller is used in conjunction with a slave board. | Make sure the control cable used in the daisy chain interface is properly shielded from noise. |
| Err 4 | The master controller has detected a change in module configuration or a fault in one of the modules. | Reinstall all modules in accordance with the instructions in the factory IOM. |
| Err 5 | If the fault described in "Err 4" is not corrected, the master controller will reconfigure the modules that are responding properly and operate at a degraded condition. | Reinstall all modules. Contact factory if the problem persists. |
| Err 6 | A message error affecting the software of the master controller or one of its modules. | Check the integrity of all connecting cables used to drive slave boards for additional solenoids. Also check the electrical grounding of the system installation. |
| Err 7 | Indicates that one of the triac drivers are not functioning. | Return to factory for evaluation and repair. |
| Err 8 | Internal Error. | Contact the factory. |
| Err 9 | Unassigned message code. | Contact the factory. |

4.0 Glossary of Terms

- **Run Mode:** The term used when the timer board is firing the solenoids.
- **Pressure Module:** The pressure measurement subsystem that includes the software and hardware for on-demand cleaning, alarms and signal retransmission of the process variable (i.e., the differential pressure across the dust bags).
- **Master Controller:** The primary timer board that contains all of the major features, connections for external inputs and power to drive the DCT1000 Dust Collector Timer Controller system.
- **Power Guard:** A plastic shield that covers the output triacs and other line voltage circuitry.
- **Demand Cycle Mode:** A process in which the run mode is enabled through the on-board pressure module or an external switch such as the Dwyer Photohelic®.
- **Euro Connector:** A "caged" connection used to terminate solenoids, incoming power, or external switches on the DCT1000.
- **Continuous Cycle Mode:** A time based cycling mode dependent on solenoid time on/off settings and time set between complete cycles.
- **Manual Override:** Allows the user to override the DCT1000 remotely or from the master controller panel through use of a switch or a wire jumper.
- **Slave Board:** A channel expander that is used in conjunction with the master controller to accommodate additional solenoids on larger dust collection systems. It can be recognized easily as it does not have the on-board display panel or the power supply present. A master controller may also be used as a slave board.

Still need help? Please feel free to contact one of our customer service representatives at 219-879-8000 or visit us on the web at www.dwyer-inst.com or www.dust-controls.com. Thank you for choosing Dwyer Instruments.

Installation and Maintenance

- To prevent injury, damage or malfunction the installation of diaphragm valves and accessories must only be performed by technically competent personnel, following these instructions.
- Make sure that electrical power is isolated from the system before installing or opening this product.
- For your safety DO NOT pressurise the system until all valves are fully secured and tightened. DO NOT attempt to remove a fitted valve while the system is under pressure.
- Wear safety glasses and personal protective equipment at all times while working on the system.
- The 40MMR, 62MMR or 76MMR valve may be supplied as part of a complete valve and manifold system. The valve body, manifold and pipe outlet are a single integral unit, and should under no circumstances be disassembled. Disassembly will lead to certification and warranty becoming void.
- Valves require inlet and outlet pipes to be restrained. The valve is not a structural member.



Warning!

CAUTION

| | | | | | | | |
|---|-----|--|----|--|-----|--|----|
| | YES | | NO | | YES | | NO |
| Mounting underneath the manifold allows oil, water and grit to become trapped in the valve, reducing reliability. | | | | | | | |

at the
only as
n:

Installation

| | |
|--|--|
| Secure the valve inlet to the manifold. | -Tighten DD nuts to 20N.m. |
| | -M valves mount on the face of the manifold, which must be flat within 0.2mm (0.008"). O rings between the valve and the manifold should be coated with a suitable silicone lubricant. |
| -MVA valve mounting template drawings are available: | 25MM P / 25MM D 40MM P / 40MM D 76MM CA102MM / RCA102MM 691055 / 691056 |
| | 690048 / 690046 690045 / 609999 690151 |
| Secure the blow tube to the valve outlet. Ensure the blow tube is supported and restrained; connection to the valve is not for blow tube support or restraint. | -76MM and 102MM should be tightened to 20N.m (14.8 lbf.ft), working in a pattern. For example – tighten every alternate screw until all are tight. |
| Remove pilot valve connections for RCA/RCA valves should be made with straight fittings where possible. Tubing bore diameter must be 3.2-4.2mm (0.13-0.17") minimum. | Electrical supply connection to the solenoid coil should match the parameters printed on the coil. Supply voltage should be in the range of nominal voltage +10% / -15%. |
| Once valve is installed, supply clean, dry air at the required pressure to the manifold, not exceeding 860kPa (125psi). | Check for leaks at all joints. |
| Check the electrical connection at the on-board or remote pilot valve enclosure. Turn on power supply. | Check valve exhaust for adequate venting and noise suppression. |
| Switch electrical control on and observe for several cycles. | |

Start Up:

MAINTENANCE

Application conditions, manifold pressures, and cycle rates can vary widely. To guarantee good operational health of the valve components we recommend annual inspection and servicing of replaceable parts as described below. Goyen recommend that appropriately qualified personnel conduct all maintenance activities

| | |
|-------------------------------|---|
| Serviceable parts are: | <ul style="list-style-type: none"> Diaphragms and springs. Pilot valve plunger and spring. Seals Solenoid coils (ensure the correct voltage is used). <p>Refer to Kit list below for ordering codes. All other items are non-serviceable.</p> |
|-------------------------------|---|

Note – valves supplied as a part of a complete manifold system should not be disassembled from the manifold. Maintenance does not require disassembly from the manifold.

| | |
|---|---|
| Main Valve maintenance procedure: | <ol style="list-style-type: none"> De-pressurise the manifold system. Isolate electrical power. Loosen the cover screws and remove diaphragm assembly / spring (if supplied). Clean all components. Check that air passages and bleed holes are clear. Exchange all worn components using the appropriate replacement kit. Assemble cover to body and tighten screws. Refer to torque values listed below. Ensure valve exterior is reasonably clean, and free from dust build-up. |
| Pilot Valve maintenance procedure: | <ol style="list-style-type: none"> De-pressurise the manifold system. Turn off the electrical power supply. Remove coil assembly. Loosen the ferrule retainer screws and remove ferrule / plunger assembly. |

RCAC20DD4 and RCAC25DD4 Reverse Valve

Installation Instructions

Dimensions – RCAC20DD4/RCAC25DD4

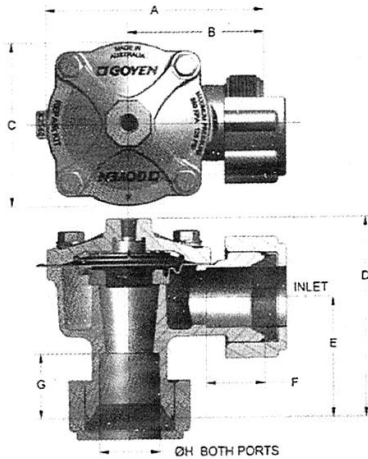

Dimensions

| Valve Model | A | | B | | C | | D | | E | | F | |
|-------------|-------|------|------|------|------|------|-------|------|------|------|------|------|
| | mm | inch | mm | inch | mm | inch | mm | inch | mm | inch | mm | inch |
| RCAC20DD4 | 103.7 | 4.08 | 66.7 | 2.63 | 74.0 | 2.91 | 81.6 | 3.21 | 44.2 | 1.74 | 25.4 | 1.00 |
| RCAC25DD4 | 124.7 | 4.91 | 77.7 | 3.06 | 94.0 | 3.70 | 115.4 | 4.54 | 69.7 | 2.74 | 33.3 | 1.31 |
| Valve Model | G | | H | | J | | K | | L | | | |
| | mm | inch | mm | inch | mm | inch | mm | inch | mm | inch | | |
| RCAC20DD4 | 25.4 | 1.00 | 27.2 | 1.07 | 20.0 | 0.79 | 41.0 | 1.61 | 48.0 | 1.89 | | |
| RCAC25DD4 | 38.1 | 1.50 | 34.2 | 1.35 | 31.7 | 1.25 | 44.4 | 1.75 | 59.0 | 2.32 | | |

Installation Distances

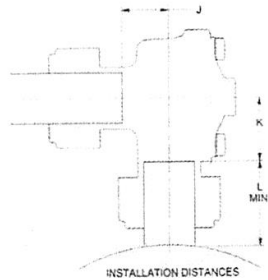

Maintenance Kits:

| Valve | Nitrile | Shockwave | Viton |
|-------------------------|---------|-----------|-------|
| Diaphragm Kit | | | |
| CA/RCAC20DD4 | N/A | K2034 | K2033 |
| CA/RCAC25DD4 | N/A | K2546 | K2551 |
| Dresser Seal Kit | | | |
| CA/RCAC20DD4 | K2008 | N/A | K2009 |
| CA/RCAC25DD4 | K2508 | N/A | K2507 |

WARNING: To prevent injury, damage or malfunction read the following instructions carefully. If in doubt, please contact your Tyco/Goyen representative for further advice.

WARNING: Wear safety glasses at all times when working on the system.

Valve Installation and Security:

- Install the valve so that the ingress of water and dust through the exhaust ports is avoided.
- Slide the valve onto the tank stub pipes and tighten the dresser nut to max. torque 22Nm (16ft/lbs). Insert blowpipes into outlet and tighten the dresser nut to maximum torque 22Nm (16ft/lbs). Check for leaks at valve inlet on system pressurisation.
- When using the DD4 valves the blowtube must be independently restrained.

WARNING: For your safety do not pressurise the system until all valves are fully secured and compression nuts tightened. Do not attempt to remove a fitted valve while the system is under pressure.

Start Up Procedure:

1. Ensure tank and air delivered are clean and free from particulate.
2. Ensure blowtube is secured, mounted and appropriately sealed at the baghouse wall.
3. Ensure that the valve is securely mounted to the pressure vessel.
4. Apply the required system pressure to pressurise vessel. **DO NOT EXCEED 860KPA (125PSI)**
5. Carefully check the installation for leaks.
6. Switch the filter cleaning controller to continuous cycle. Observe several operations and check for correct firing sequence.

Operation:

Recommended on time range: 50-500ms.

Recommended time between pulses: 1 minute or greater.

Français

AVERTISSEMENT: Pour éviter toute blessure, dommage ou dysfonctionnement, veuillez lire attentivement les instructions suivantes.

En cas de doute, veuillez contacter un représentant de Tyco / Goyen pour de plus amples conseils.

AVERTISSEMENT: Veuillez porter en permanence des lunettes de sécurité lorsque vous travaillez sur le système.

Installation de la Valve et Sécurité:

- Installez la valve de telle sorte que l'eau ou la poussière ne puissent pénétrer à l'intérieur des orifices d'échappement.
- Glissez la valve sur les conduits d'échappement du réservoir et serrez l'écrou de raccord rapide avec un couple maximum de 22Nm (16ft/lbs). Insérez les busillons dans la sortie et serrez l'écrou de raccord rapide avec un couple maximum de 22Nm (16ft/lbs). Vérifiez qu'il n'y a pas de fuites à l'entrée de la vanne sur le système de pressurisation.
- En cas d'utilisation de DD4, le busillon doit être maintenu de façon indépendante.

AVERTISSEMENT: Pour votre sécurité, ne pressurisez pas le système tant que toutes les vannes ne sont pas entièrement fixées et les écrous de compression serrés. N'essayez pas de démonter une vanne en place alors que le système est sous pression.

Procédure de démarrage:

1. Assurez-vous que le réservoir et l'air fourni sont propres et exempts de particules.
2. Assurez-vous que le conduit d'expulsion est solidement fixé, monté et dûment scellé au mur du filtre à manches.
3. Assurez-vous que la vanne est solidement fixée au réservoir sous pression.
4. Appliquez la pression de système nécessaire pour pressuriser le réservoir. **NE PAS DÉPASSER 860KPA (125PSI)**
5. Vérifiez soigneusement que l'installation ne présente pas de fuite.
6. Basculez le contrôleur de nettoyage du filtre en cycle continu. Observez plusieurs opérations et vérifiez que la séquence d'allumage est correcte.

Fonctionnement:

Plage de temps conseillée : 50-500ms.

Temps recommandé entre les impulsions : 1 minute ou plus.

Pour les dimensions, consultez la Figure 1

Pour les distances d'installation, consultez la Figure 2

609594

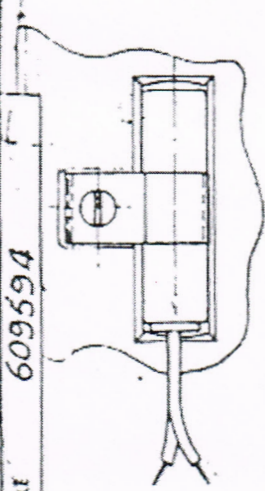

TOP VIEW
M100

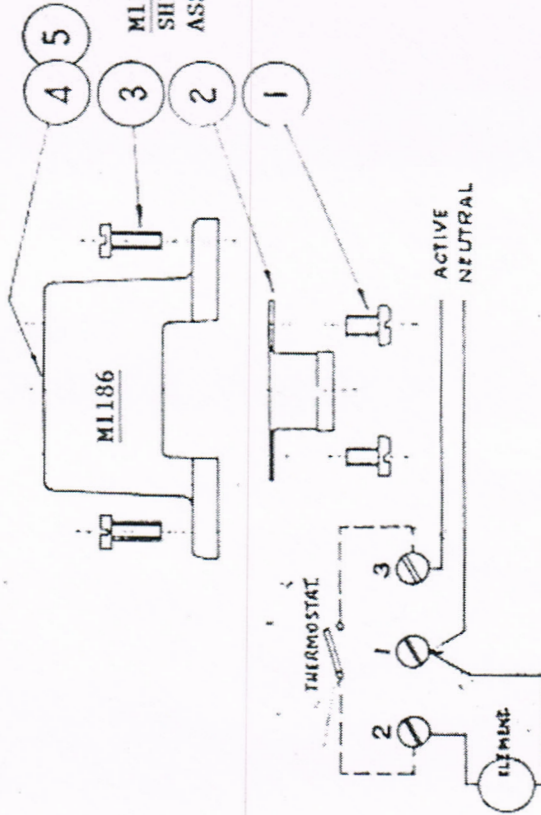

M1186
SHIPPED FULLY
ASSEMBLED

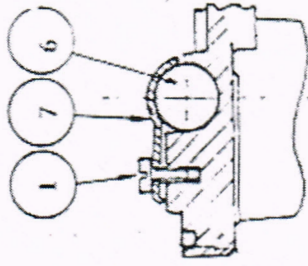

END VIEW
M100

| ITEM | PART N ^o | DESCRIPTION | P | N ^o |
|------|---------------------|-------------------|---|----------------|
| 7 | 609286 | RETAINING CLIP | | 1 |
| 6 | M100 | HEATER ELEMENT | P | 1 |
| 5 | M1800 | SCREW 8UNC. X 3/8 | P | 3 |
| 4 | D 60455-1 | TERMINAL BLOCK | | 1 |
| 3 | M1530 | SCREW 6UNC. X 3/8 | P | 2 |
| 2 | M1725 | THERMOSTAT | P | 1 |
| 1 | M1801 | SCREW 8UNC. X 1/4 | P | 3 |
| | PART N ^o | DESCRIPTION | P | N ^o |

PART NUMBER TABLE

GOYEN CONTROLS CO. PTY. LIMITED

268-292 MILPERRA ROAD, MILPERRA, SYDNEY, 2214

1/2 DIA. HEATER ACCESSORY KIT

| | | | |
|----------|--|---------------|--|
| MATERIAL | M1186 THERMOSTAT | FIRST USED ON | ALL DIMENSIONS IN INCHES UNLESS OTHERWISE STATED |
| | M100 ELEMENT | | TOLERANCES: FRACTIONAL SIZE ± .010" DECIMAL DIMENSIONS ± .002" UNLESS OTHERWISE SPECIFIED |
| | REMOVE ALL BURS, FLASH AND SHARP EDGES | | |
| | REPLACEMENT | | |

| | | | |
|--------|-----------|---------|----------|
| Scale | Full Size | A/C | |
| Traced | Drawn | Checked | Approved |
| Date | 13-6-78 | | |

E

609594

RAIN-TIGHT AND DUST-TIGHT ENCLOSURES

Description:

Enclosures are suitable for ATEX Category Ex II 3GD, IP65 and other non-hazardous applications, for piloting Goyen diaphragm valves.

Product Markings:

CE ATEX II 3GD
Ex nA II T6 Gc
Ex tc IIIC T55°C Dc IP65

Supplier's Declaration of Conformity # DoC 005/2012

Operating Parameters:

| | | | |
|--------------------------------|-------------------|---|---------------|
| Maximum Operating Pressure | 860 kPa (125 psi) | Minimum Temperature | -40°C (-40°F) |
| Recommended Operating Pressure | 760 kPa (110 psi) | Maximum Temperature | 82°C (180°F) |
| Minimum Operating Pressure | 30 kPa (5 psi) | The valves are to be used to pulse air or inert gas only. | |

Restrictions: This product's certifications are valid only for product that has not been modified since leaving the Goyen factory. Modifications made to the enclosure such as the fitment of additional gaskets, the addition or removal of pilot valves and coils, changes in markings, or physical modifications made to the enclosure itself will invalidate the product certifications. Only activities described in 'Installation' and 'Maintenance' may be conducted without affecting the certification of the product.

Product Identification:

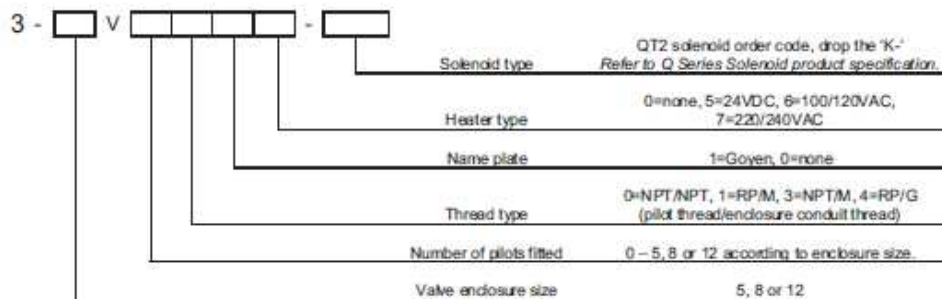

Example: 3-8V6010-330

8 valve enclosure, fitted with 6 pilots, with NPT pilot and conduit thread type, Goyen name plate, no heater element and 220/240VAC 50/60Hz solenoids.

Note that enclosures are pre-wired with QT2 type solenoids only.

Note: ATEX/CSA Certification is not valid if a heater element is installed.

| | |
|--|---|
| <p>USA Goyen Valve Corporation Telephone 732 364 7800</p> | <p>CHINA Pentair Water & Environmental Systems Telephone 86 21 5239 8810 Fax 86 21 3211 4582</p> |
| <p>UNITED KINGDOM Pentair Environmental Systems Ltd. Telephone 44 1256 817 800 Fax 44 1256 332 760</p> | <p>MALAYSIA Goyen Controls Co. Pty. Ltd. Telephone 60 3 7987 6839 Fax 60 3 7987 7839</p> |
| <p>GERMANY Pentair Umweltechnik GmbH Telephone 49 6432 95299-0 Fax 49 6432 95299-24</p> | <p>ITALY Mecair S.r.l Telephone 39 0362 3751 Fax 39 0362 367 279</p> |
| <p>AUSTRALIA Goyen Controls Co. Pty. Ltd. ABN 60 000 168 098 268 Milperra Road, Milperra NSW 2214 Telephone 1800 805 372 Fax 1300 658 799 http://www.cleanairsystems.com</p> | |

RAIN-TIGHT AND DUST-TIGHT ENCLOSURES

INSTALLATION

WARNING! Ensure that the enclosure is correctly assembled with all cover screws tightened between 1.7 – 2.5 Nm (15 – 22 lbf-in) prior to applying power. Keep cover closed while circuits are live.

WARNING! Wear safety glasses at all times when working on the system.

WARNING! Refer to EN 1127-1 for the restrictions on tools which may be used if working in an explosive atmosphere.

Mounting: Enclosures should be mounted in a horizontal position, where the pilot valves and solenoid assemblies are in the preferred vertical orientation.

Electrical connections: Refer to diagram. (Typical example of 3-5V wiring)

The included Goyen QT2 solenoids are provided with screw terminals. These solenoids are neutrally linked at the factory for customer convenience.

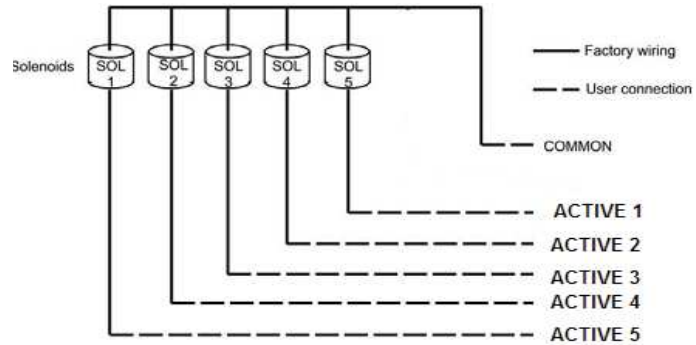

Grounding Terminal: The internal grounding terminal must be used for the equipment grounding connection.

Cable Entry: Appropriate cable glands or conduit must be used. Thread options are listed in the product identification table on page 1.

For the 3-5V enclosure, entry options are: M20, 1/2" NPT, 1/2" G.

For the 3-8V & 3-12V enclosures, entry options are: M25, 3/4" NPT, 3/4" G.
(An appropriate blanking plug must be fitted if a cable entry port is not used).

Heater Option: The 3-8V & 3-12V enclosures can be fitted with an internal heater to reduce condensation. The heater is thermostatically controlled between 10°C and 24°C (50°F to 75°F).

Note: Heater Option is not available with ATEX or CSA approval

1. Heater retaining clip
2. Heater element
3. Wiring terminal block
4. Thermostat element

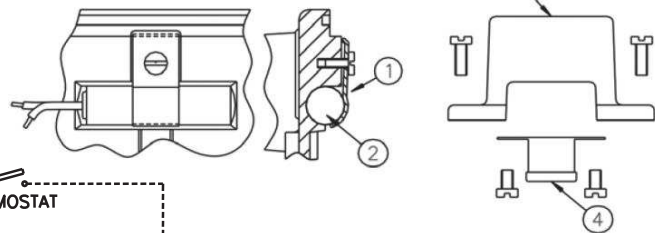

Heater voltage options

| | |
|------------|------|
| 220/240vac | 100W |
| 110/120vac | 100W |
| 24vdc | 48W |

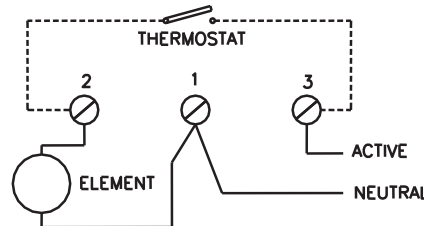

Pneumatic connections: Connect these pilot valves to the dust collector reverse pulse jet valves using metric 4 mm ID tubing (.157" ID) or 1/4" tubing (.162" ID) and a maximum length of 1.5 m (4.9 ft). A maximum of 8.0 Nm (70 lbf-in) may be used when installing fittings in the valve's inlet or exhaust port.

RAIN-TIGHT AND DUST-TIGHT ENCLOSURES

Solenoid performance: Refer to the table below

| Voltage & Frequency | Inrush Current | Hold Current | Power |
|--------------------------------|-----------------------|---------------------|--------------|
| 220v 50Hz / 240v 60Hz | 148 / 143 mA | 105 / 94 mA | 23.1 VA |
| 100v 50Hz / 120v 60Hz | 234 / 255 mA | 180 / 152 mA | 19.8 VA |
| 24v 50/60Hz | 1338 / 1096 mA | 963 / 716 mA | 23.1 VA |
| 110v DC | 212 mA | 212 mA | 24 W |
| 24v DC | 873 mA | 873 mA | 20 W |

Electrical pulse times:

“On-time” range from 50 to 500 milliseconds. Minimum “off-time” of 1 minute.

MAINTENANCE

Annual maintenance of serviceable parts is recommended. Refer to maintenance kits table listed below. Damaged coils may be replaced (ensure the same voltage is used). All other items are non-serviceable. Goyen recommend that appropriately qualified personnel conduct all maintenance activities. Certification of qualified maintenance staff and facilities may be required under some certification schemes. Inappropriate service invalidates the product certifications.

Mounting screws for pilot body to be tightened to 1.5 Nm (1 lbf-ft).

Securing nuts for pilot valves to be tightened to 13Nm (9.5 lbf-ft).

Cover mounting screws to be tightened between 1.7 – 2.5 Nm (1.3 – 1.8 lbf-ft).

SPARE PARTS

| Coil Kits (Single Coil) | |
|--------------------------------|--------------------|
| Part No. | Description |
| K0330 | 220/240v AC |
| K0331 | 100/120v AC |
| K0332 | 24v AC |
| K0334 | 110v DC |
| K0336 | 24v DC |
| K0337 | 12v DC |

| Maintenance Kits | |
|-------------------------|---|
| Part No. | Description |
| K0380 | Nitrile replacement seal, armature, spring and ferrule kit. |
| K0384 | Viton replacement seal, armature, spring and ferrule kit. |

CONSTRUCTION DETAILS

| | |
|--------------------------|---|
| Base, cover & pilot body | Aluminium (diecast) |
| Ferrule | 305 stainless steel |
| Armature | 430FR stainless steel |
| Seals | Nitrile rubber |
| Screws | 304 stainless steel |
| Coil clip | Spring steel (plated) |
| Solenoid | Goyen type QT2 (purple) Class B (130°C) self-extinguishing Nylon PA-6 |

RAIN-TIGHT AND DUST-TIGHT ENCLOSURES

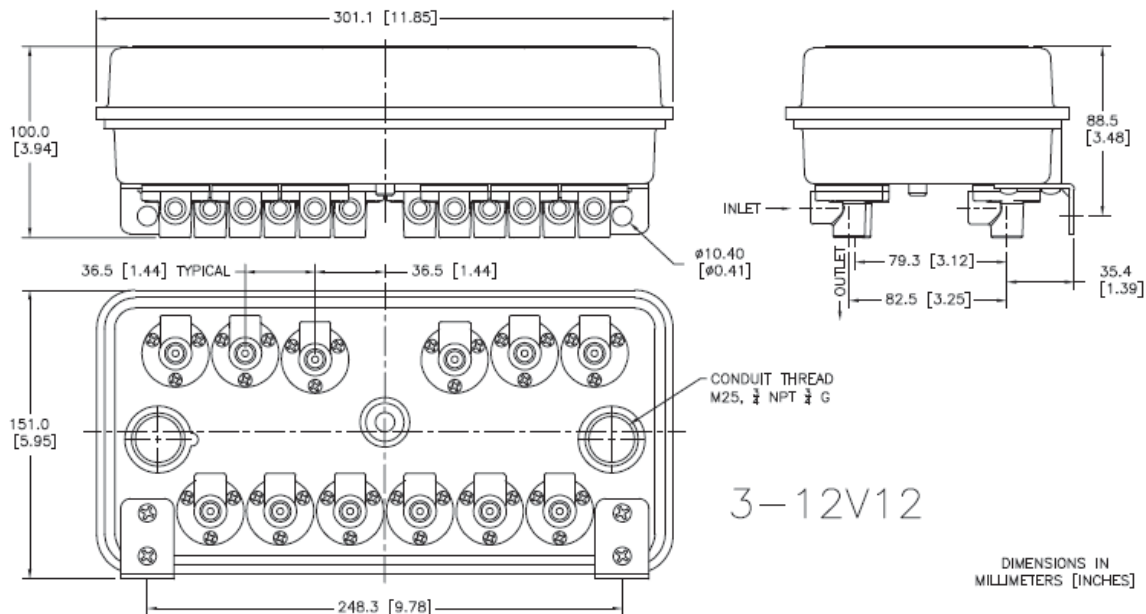
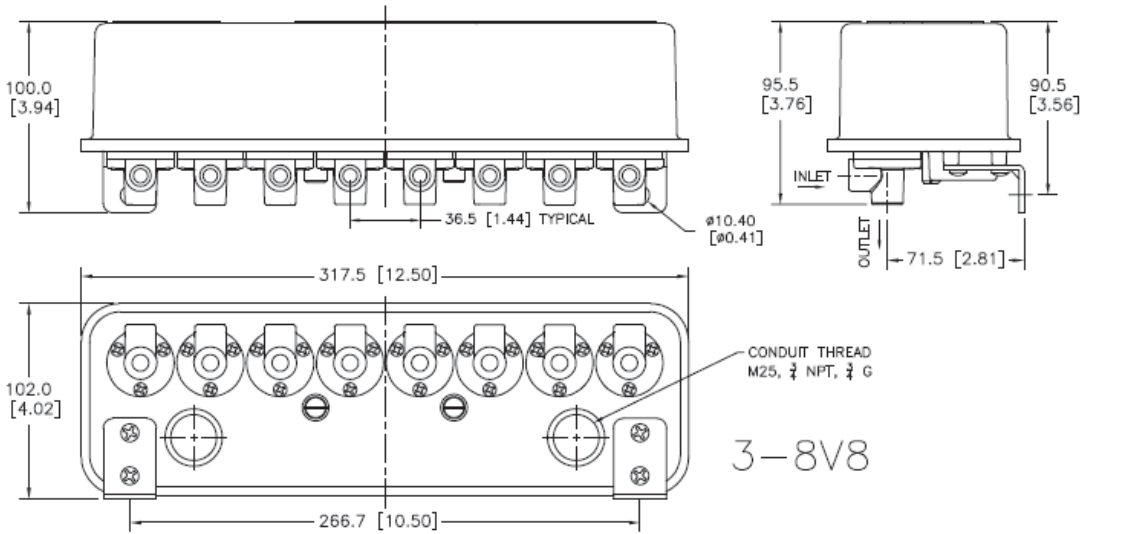
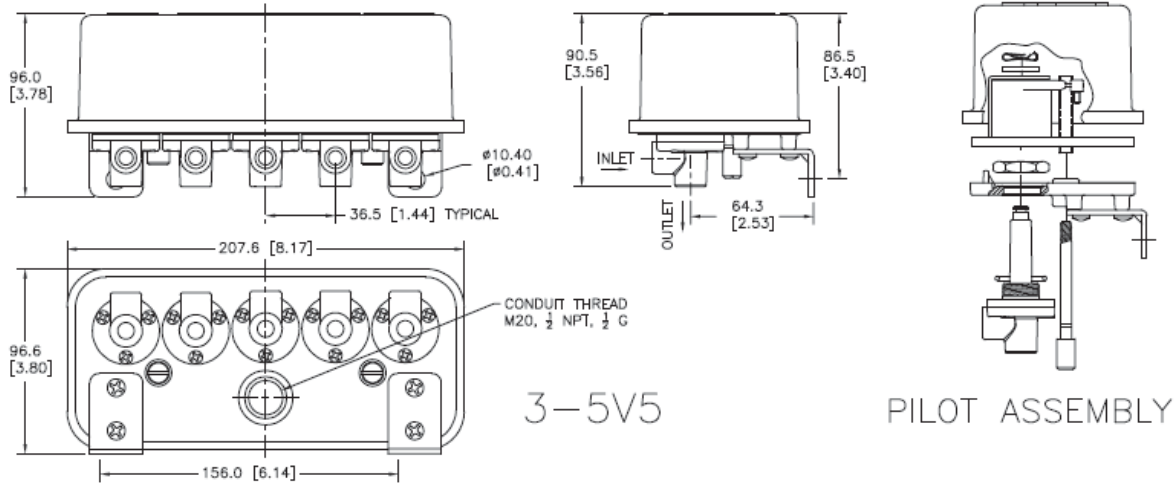

DIMENSIONS IN
MILLIMETERS [INCHES]

Contents

| | |
|--|---|
| Introduction | 1 |
| Shipping and Receiving..... | 1 |
| Handling | 1 |
| Short Term Storage..... | 2 |
| Long Term Storage..... | 2 |
| Foundations and Supporting Structures..... | 2 |
| Fan Installation | 2 |
| Factory Assembled Units | 2 |
| Disassembled Units..... | 3 |
| Fan Operation – Safety..... | 4 |
| Operation Checklist..... | 5 |
| Maintenance of Fans..... | 5 |
| General Motor Maintenance..... | 5 |
| Drive Maintenance..... | 5 |
| Bearing Maintenance..... | 5 |
| Lubrication..... | 6 |
| Wheel and Shaft Maintenance..... | 7 |
| Structural Maintenance | 7 |
| Troubleshooting Guidelines..... | 7 |
| Troubleshooting Performance Problems | |
| Air Capacity Problems..... | 7 |
| Noise Problems | 7 |
| Vibration Problems..... | 7 |
| Motor Problems..... | 7 |
| Drive Problems | 7 |
| Bearing Problems..... | 8 |
| Limitation of Warranties and Claims | 8 |

Introduction

The purpose of this manual is to provide instructions that complement good general practices when installing or operating fans manufactured by Twin City Fan & Blower. It is the responsibility of the purchaser to provide qualified personnel experienced in the installation, operation, and maintenance of air moving equipment.

Instructions given in the body of this manual are general in nature and apply to a variety of models manufactured by Twin City Fan & Blower. Most units can be installed and maintained with the instructions given. Additional product and engineering information is available at www.tcf.com.

Special applications may require additional information. These instructions are supplied in the form of attached appendices. Use the instructions in the appendix if the directions in this manual differ from instructions in the appendix.

As always, follow good safety practices when installing, maintaining and operating your air moving equipment. A variety of safety devices are available. It is the user's responsibility to determine adequate safety measures and to obtain the required safety equipment.

Shipping and Receiving

All Twin City Fan & Blower products are carefully constructed and inspected before shipment to insure the highest standards of quality and performance.

Compare all components with the bill of lading or packing list to verify that the proper unit was received.

Check each unit for any damage that may have occurred in transit. Any damage should be reported

immediately to the carrier and the necessary damage report filed.

Handling

Handling of all air moving equipment should be conducted by trained personnel and be consistent with safe handling practices. Verify the lift capacity and operating condition of handling equipment. Maintain handling equipment to avoid serious personal injury.

Units shipped completely assembled may be lifted with slings and spreader bars. Use well-padded chains, cables or nylon straps. On most units, lifting lugs are provided for attaching chains (see Figure 1). Lift the fan in a fashion that protects the fan and fan coating from damage. Never lift a fan by the inlet or discharge flange, shafting or drives, wheel or impeller, motor or motor base, or in any other manner that may bend or distort parts.

Partial or disassembled units require special handling. All parts should be handled in a fashion which protects the coatings and parts from damage. Components should be handled such that forces are not concentrated and bending or distortion cannot occur.

Figure 1. Lifting Lug Locations

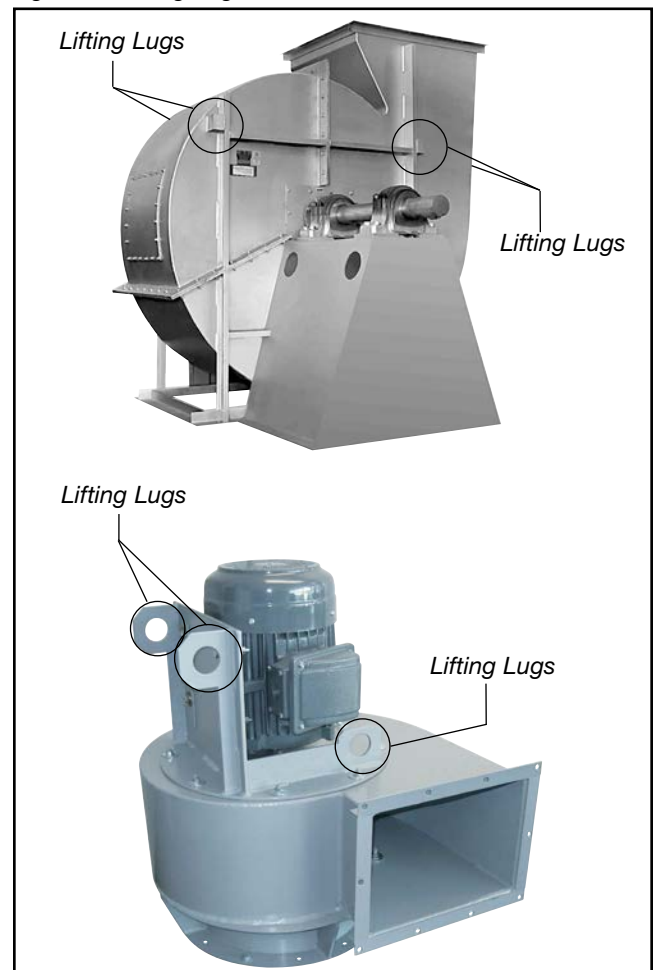

Housing should be lifted using straps and spreaders. Do not distort housing or side plates when lifting.

Bearing pedestals should be lifted using straps or padded chains. Under no circumstances should an attached or separated bearing pedestal be lifted by the shaft, bearings, drives, motor or wheel.

The shaft and wheel assembly may be lifted using a hoist and a spreader with a sling around the shaft at points nearest the wheel (see Figure 2). Take care not to scratch the shaft where the wheel or bearings will be mounted. Never lift or support the assembly by the wheel. Always support the assembly by the shaft when lifting or storing. Do not support the shaft or the wheel on housing sides. Use only the key provided with the shaft and wheel.

Figure 2. Moving Shaft and Wheel with Spreader Bar

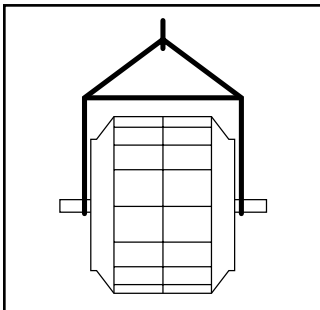

Wheels shipped separately can be lifted by slings running through the blades and around the hub. Never lift the wheel by blades or flanges. Always transport wheels by lifting. Do not roll the wheel as this can damage coatings and change the balance of the wheel.

Bent shafting is a source of vibration and bearing failure, so handle the shaft with care. Any scratches on the shaft may be removed with fine emery cloth or a stone.

Short Term Storage

If fan installation is to be delayed, store the unit in a protected area. Protect the fan and motor bearings from moisture and vibration (or shock loading).

Long Term Storage

Prior to Storage – Fan bearings (and motor bearings per the motor manufacturer's specifications) are to be greased at the time of going into extended storage. On belt drive units the belt tension should be reduced to less than half the specified value for the fan's design to prevent a sag/set from forming in the shafts and belts.

If the unit was supplied with a motor, the motor windings should be measured at this time and recorded for comparison prior to placing in service. If the fan housing was supplied with a drain connection, this plug should be removed to prevent any moisture from accumulating in this portion of the unit during storage.

Storage Procedure – Fans should be stored indoors whenever possible where control over temperature, shock and dust is reasonably maintained. If units are to be stored outside in the elements, they should be covered with a water-resistant material. The bearings should be shielded individually from water and dirt; however, do not tightly seal to avoid trapping condensation. Stored equipment should be stored on a clean, dry floor or blocked up off the ground on blocks to prevent unit from setting in any water or directly on the ground. If shock or vibration will be present during storage, the unit may need to be placed on some type of vibration dampening material to aid in preventing brinelling of the bearing surfaces.

Periodic Check – On a monthly interval, the equipment should be checked to ensure that it has remained in an acceptable stored condition. The fan (and motor if supplied) should be rotated several times by hand while adding enough grease to replenish the bearing surfaces with fresh grease and to maintain a full bearing cavity. Grease

used must be compatible with that already supplied in the motor and fan bearings. The fan impeller should be left at approximately 180 degrees from that of the previous month to prevent the shaft and impeller from taking a set in one position. Storage records should be maintained which indicate the above requirements have been followed. Consult the motor manufacturer for proper storage, space heater connection and lubrication if the unit was supplied with one.

Start-Up – When the unit is removed from storage, all fan bearing grease should be purged and replenished with fresh grease as per the lubrication decal. The motor should be measured to verify that the resistance is still at a satisfactory level compared to the value recorded prior to storage. Spherical roller bearings with split pillow block housings should be recharged with grease. The bottom half of the housing should be 1/3 full.

Foundations and Supporting Structures

Floor mounted fans should be installed on a flat, level, rigid concrete foundation with a mass at least three to five times that of the assembly supported as a guide, depending on the size and speed of the fan. Foundation shall be suitable for static and dynamic loads and foundation frequencies be separated at least 20% from the rotational speed/speed ranges. The plan area should be no more than twice that required by the equipment. Foundations with larger areas should have correspondingly larger mass. Anchor bolts should be "L" or "T" shaped with sufficient length for nuts, washers, shims, and threads for draw-down. Each bolt should be placed in a sleeve or pipe with a diameter larger than the bolt to allow for adjustment.

If the fans are mounted on a sub-structure, an inertia base with spring isolator system should be considered.

Fans mounted to or within a structure should be placed as close as possible to a rigid member such as a wall or column. The structure must be designed for rotating equipment; static design for strength is not sufficient to insure proper operation. Supports for suspended fans must be cross-braced to prevent side sway. Structural resonance should be at least 20% from fan operating speed. Vibration isolators should be used where applicable.

Any ducting should have independent support; do not use the fan to support ducting. Isolating the fan from ductwork with flex connections eliminates transmission of vibration. Fans handling hot gases require expansion joints at both the inlet and discharge to prevent excessive loads caused by thermal growth.

For fans requiring concrete filled bases or pedestals, please refer to Twin City Fan's installation and maintenance manual "Heavy Duty Centrifugal Fans - ES-995" for instructions.

Fan Installation – Factory Assembled Units

Follow proper handling instructions given earlier.

1. Move the fan to the final mounting position.
2. Remove skid, crates, and packing materials carefully.
3. If supplied, place vibration pads or isolation base on mounting bolts. Line up holes in fan base with bolts.
4. Place fan on mounting structure. Carefully level unit using shims as required at all mounting hole locations. Bolt down the unit. Be careful not to force the fan to conform to the mounting structure/foundation. This may cause the bearings to become misaligned or pinched causing vibration and premature failure.
5. Any grout may now be used. Bolt the fan in position before applying grout. Do not depend upon grout to support rotating equipment.
6. Continue with Operations Checklist.

Additional instructions may be given for some fan models, components and accessories in the appendix.

Fan Installation – Disassembled Units

A unit is considered “disassembled” if any component required for proper operation is shipped or supplied separately or in pieces. Reference earlier instructions concerning proper handling of fan components.

Instructions for Mounting and Assembly of Unit:

1. Move lower housing/framework to mounting location.
2. If vibration pads or bases are used, place on bolts first. Place lower housing assembly onto bolts.
3. Level and shim if required. Bolt into place.
4. If separated pedestal or bearing pedestal:
 - a. Bring bearing pedestal to desired location.
 - b. Place any vibration base or pads into place. Set bearing pedestal on bolts.
 - c. Never distort bearing pedestal by forcing it to align with a non-level surface. Shim beneath the pedestal as required.
 - d. Check bearing centerline height. Change centerline height to match centerline height of housing. High temperature units may require the housing centerline to be lower when cold so that it will be centered when hot.
 - e. Measure from housing to bearing pedestal to bring bearing pedestal into square with housing (a large square may also suffice).
 - f. Bolt into position.
5. Shaft and wheel assembly preparation:
 - a. Clean protective coating off shaft with solvent. Do not touch clean areas of shaft with hands. Perspiration can cause rust or pitting over time.
 - b. Remove keys from shaft.
 - c. Clean inside of wheel bore with solvent. Make sure setscrews will not interfere when inserting shaft into wheel bore.
6. Arrangement 1, 9 or 10: Drive Component Assembly (See Figure 3):
 - a. Insert shaft into wheel from back side of wheel.
 - b. When shaft is flush with wheel hub, put key into keyway and tighten wheel setscrews.
 - c. Insert shaft through opening in drive side. (If split housed unit, lower into position.)
 - d. Install bearings onto shaft. Do not tighten bearing setscrews at this time. The bearing housing should be perpendicular and the bearing base parallel to the axis of the shaft to prevent loads caused by misalignment.
 - e. Mount assembly, bolt bearings to drive stand. Shaft

Figure 3. Drive Component Assembly

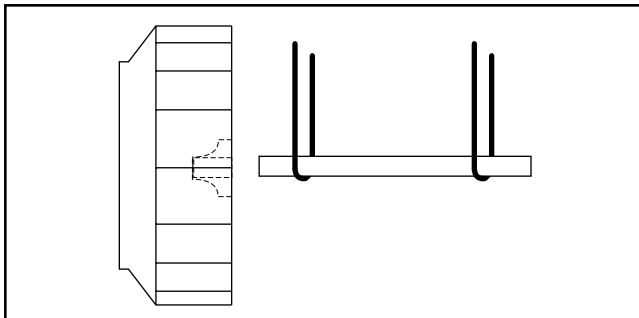

must be parallel with side of bearing pedestal. Precision shim bearings as required. After aligning and bolting bearings to pedestal, lock bearings. Be sure expansion bearing (if supplied) is set to allow for growth. Continue with step 8.

7. Arrangement 3 (Split-housed) units (See Figure 4):
 - a. Parts on DWDI units are assembled in the following order as viewed from opposite drive side: Bearing bar assembly and opposite bearing, funnel, (housing side), wheel, (housing side), funnel, drive side bearing bar assembly, drive bearing and sheaves. Mount bearing bar assembly to housing. Center wheel in funnels.
 - b. Parts on SWSI units are assembled in the following order as viewed from opposite drive side: Bearing bar assembly and opposite bearing, funnel, (housing side), wheel, (housing side), drive side bearing bar assembly, drive bearing and sheaves. Mount bearing bar assembly to housing. (See Figure 7 for wheel-funnel overlap.)
 - c. Assemble parts in above order on shaft.
 - d. Move assembly into position. Lightly bolt bearings into place.
 - e. Shaft should be parallel with discharge of housing. Move bearings to accommodate.
 - f. Level shaft; shim bearings if required. Lock bearings. Be sure expansion bearing (if supplied) is set to allow for shaft growth.
8. Install motor on base. Carefully align shafts for drive installation.

Figure 4. Split-housed Drive Component Assembly

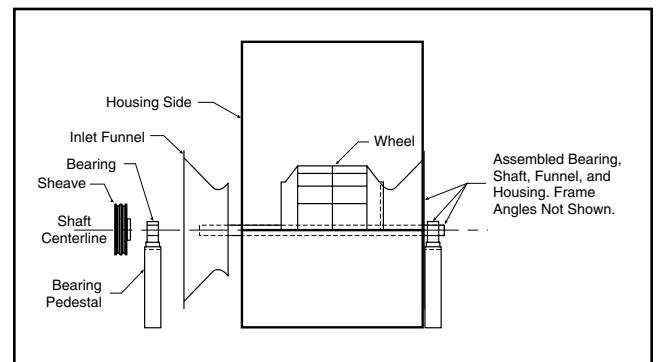

9. Mount drives as follows: **Figure 5. Sheave Position**

- a. Slip (do not pound) proper sheave onto corresponding shaft. **CAUTION: PLACING FAN SHEAVE ON MOTOR CAN OVERSPEED WHEEL AND CAUSE STRUCTURAL FAILURE.**

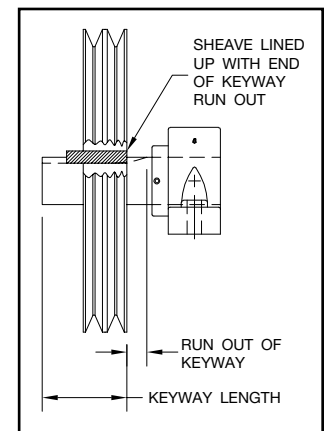

- b. Position sheaves so they are placed on motor shaft and fan shaft as close as possible to the motor and/or bearing. Sheave must be placed so that it does not rub on the bearing, motor guard or other structures. On keyed shafts,

Figure 7. Wheel-Funnel Overlap

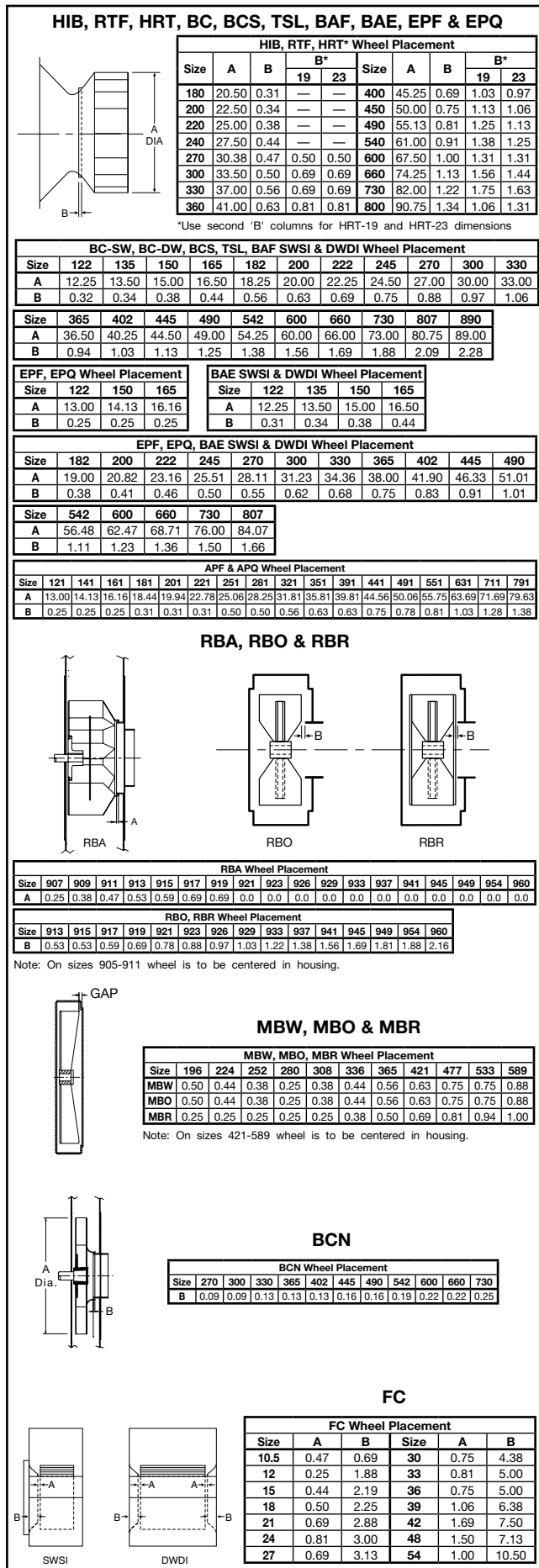

the key should be placed in the keyway pushed toward the bearing as far as the runout will allow without rubbing. The back of the sheave should be lined up with the end of the key (see Figure 5 on page 3). For sheaves without a key, the sheave should be placed as close to motor and/or bearing as possible without rubbing. Typically the sheave should be at least 1/4" away from the motor, bearing, guard, structures, etc.

Figure 6. Sheave Alignment

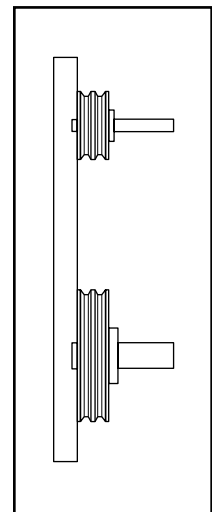

- c. Align sheaves with a straight-edge extended along the perimeters of both sheaves, just making contact in two places on outside perimeters of both sheaves (see Figure 6).
- d. Tighten down sheave bolts.
- e. Install a matched set of belts. Slide the motor to obtain slack and tighten belts. Using a pry will damage belts.
- f. Tighten belts to proper belt tension. Ideal tension is just enough tension so that belts do not slip under peak load. Recheck sheave alignment.
- g. After initial installation of belts, recheck belt tension again after a few days to adjust belt tension. (New belts require a break-in period of operation.)
10. Install any safety devices or accessories supplied. (Accessories commonly used are inlet vanes, shaft seals and shaft coolers, plugs, dampers, and inlet or discharge screens. Refer to appropriate documents in appendix.)
11. Grout may now be applied. Grout is used to distribute loads and should not be used as the sole support of any rotating equipment.
12. When connecting the fan to the system, it is recommended that the inlet and discharge be isolated from the system with flex connections (where practical) to block transmitted vibration. All duct connections to the fan should be independently supported. Do not use fan to support duct.

Fan Operation - Safety

For general safety practices for air moving equipment, see AMCA Bulletin 410.

Twin City Fan & Blower has many safety accessories available. These safety devices include (but are not limited to) belt guards, shaft guards, inlet and discharge screens. The use, abuse, or non-use of safety devices is the responsibility of the purchaser.

Facility-related safety conditions include fan accessibility and location. How easily can non-service personnel access the unit? Is the fan in a hazardous duty environment? Was the unit ordered for this duty? Other concerns must also be addressed. All fans should be powered through switches which are easily accessible to service personnel from the fan. Every switch should have the ability to be "locked-off" by the service person and the key to be retained by this person to prevent accidental power of the fan while service is in process.

Operation Check List

Verify that proper safety precautions have been followed:

- Electrical power must be locked off.

Check fan mechanism components:

- System connections are properly made and tightened.
- Bearings are properly lubricated.
- Wheel, drives and fan surfaces are clean and free of debris.
- Rotate the impeller by hand to verify it has not shifted in transit.
- Check fan/wheel overlap. (See Figure 7.)
- Drives on correct shafts (not reversed).
- Check position of guards to prevent rubbing.

Check fan electrical components:

- Motor is wired for proper supply voltage.
- Motor was properly sized for power and rotational inertia of rotating assembly.
- Motor is properly grounded.
- All leads are properly insulated.

Trial "bump":

- Turn on power just long enough to start assembly rotating.
- Check rotation for agreement with rotation arrow. Does the assembly make any unusual noise? (See Figure 8.)
- Check drive alignment and tension. Does this meet with drive manufacturer's recommendations?
- Correct any problems which may have been found. (Follow safety guidelines - shut power off.) Perform checklist again until unit is operating properly.
- Run unit up to speed.

Figure 8. Proper Wheel Rotation

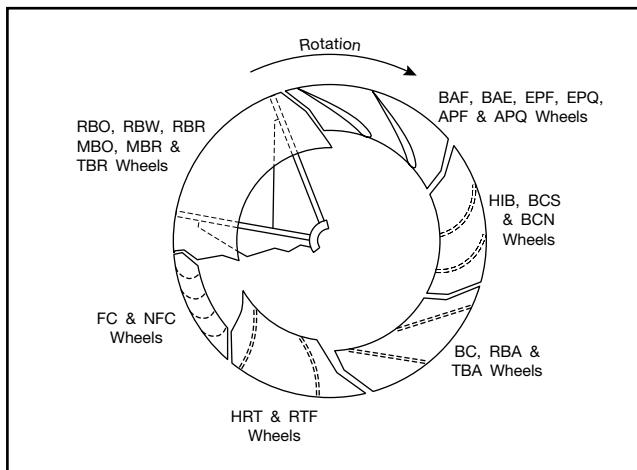

Verify fastener tightness. These may have loosened during shipment or installation.

- Setscrews attaching wheel hub to shaft.
- Setscrews in drive sheaves or coupling.
- Nuts on inlet funnel.
- Nuts and bolts holding motor.
- Nuts holding housing frame to base and base to ground.
- Nuts on accessories including shaft seal, access doors and pie-splits.
- Bolts in taper-lock bushings.
- Grease line connections.
- After one week of operation, check all nuts, bolts and setscrews and tighten if necessary.

Maintenance of Fans

This section contains general maintenance instructions for your Twin City Fan & Blower unit. For specific information about maintenance of components, particularly for special application fans, see the attached documents.

General Motor Maintenance

The three basic rules of motor maintenance are keep the motor clean, dry and properly lubricated.

Keeping motors and windings clean is important because dirt and dust serve as thermal insulators. Heat normally dissipated by the motor is trapped causing overheating and/or premature failure. Blow dust and dirt out of windings and off the motor periodically. Use low pressure (50 psig) airstream so that winding damage does not occur. Keep the area surrounding the motor open so the air can circulate through the motor cooling fan. Follow normal maintenance schedule given to the right.

Motors should be kept dry to avoid electrical short circuits. Motors kept in storage for long periods of time can have moisture condense on the windings. Be certain the motor is dry before using.

Some smaller motors are lubricated for life. Motor bearing lubrication, if required, must follow a rigorous schedule. Motors less than 10 hp running about eight hours a day in a clean environment should be lubricated once every five years; motors 15 to 50 hp, every 3 years; and motors 50 to 150 hp, yearly. For motors in a dusty or dirty environment or running 24 hours a day, divide the service interval by 2. If the environment is very dirty or high temperatures exist, divide the service interval by 4. Lubrication requirements are normally attached to the motor. Do not overlubricate.

Motors controlled by variable frequency drives (VFDs) should be wired in accordance with VFD manufacturer's instructions. The motor must be grounded to earth and proper shielded cabling must be used. Grounding rings should be considered.

Drive Maintenance

V-belt drives need periodic inspection and occasional belt replacement. When inspecting drives, look for dirt buildup, burrs or obstructions which can cause premature belt or drive replacement. If burrs are found, use fine emery cloth or a stone to remove the burr. Be careful that dust does not enter the bearings.

Check the sheaves for wear. Excessive slippage of belts on sheaves can cause wear and vibration. Replace worn sheaves with new ones. Carefully align sheaves to avoid premature sheave failure.

Observe belts for wear. If fraying or other wear is observed to be mostly on one side of the belts, the drives may be misaligned. Reinstall the drives according to instructions given for Fan Installation - Disassembled Units. Never use belt dressing on any belts.

When replacing belts, replace the entire set. After initial replacement and tensioning, recheck belt tension after a few days to adjust belt tension again. (New belts require a break-in period of operation.)

Bearing Maintenance

For instructions covering special lubrication intervals, bearing assembly or disassembly, or installation details, see attached documents. Any bearing which is disassembled should be kept separate from other bearing parts as components may not be interchangeable. Maintain cleanliness of components and bearings to prevent bearing contamination.

Figure 9. Safety & Lubrication Instructions for Fans with Ball Bearings

WARNING

- This equipment must not be operated without proper guarding of all moving parts. While performing maintenance be sure remote power switches are locked off. See installation manual for recommended safety practices.
- Before starting: Check all setscrews for tightness and rotate wheel by hand to make sure it has not moved in transit.

| Relubrication Schedule (Months)* Ball Bearing Pillow Blocks | | | | | | | | | |
|--|-------------|------|------|------|------|------|------|------|------|
| Shaft DIA | Speed (RPM) | | | | | | | | |
| | 500 | 1000 | 1500 | 2000 | 2500 | 3000 | 3500 | 4000 | 4500 |
| 1/2" thru 1 1/16" (13 – 45) | 6 | 6 | 5 | 3 | 3 | 2 | 2 | 2 | 1 |
| 1 1/16" thru 2 7/16" (50 – 60) | 6 | 5 | 4 | 2 | 2 | 1 | 1 | 1 | 1 |
| 2 1/16" thru 2 5/16" (65 – 75) | 5 | 4 | 3 | 2 | 1 | 1 | 1 | | |
| 3 7/16" thru 3 5/16" (80 – 100) | 4 | 3 | 2 | 1 | 1 | | | | |

* Suggested lubrication interval under ideal continuous operating conditions. Relubricate while running, if safety permits, until some purging occurs at seals. Adjust lubrication frequency depending on conditions of purged grease. Use one-half of listed interval for vertical shaft applications or for 24 hour operation. Hours of operation, temperature, and surrounding conditions will affect the relubrication frequency required.

- Lubricate with a high quality NLGI No. 2 lithium-base grease having rust inhibitors and antioxidant additives, and a minimum oil viscosity of 500 SUS at 100°F (38°C). Some greases having these properties are:
 Shell - Gadus S2 V100 2 Exxon - Ronex MP
 Mobil - Mobilith SHC100 Mobil - Mobilith SHC220
- Lubricate bearings prior to extended shutdown or storage and rotate shaft monthly to aid corrosion protection.

Figure 10. Safety & Lubrication Instructions for Fans with Unit Roller Bearings

WARNING

- This equipment must not be operated without proper guarding of all moving parts. While performing maintenance be sure remote power switches are locked off. See installation manual for recommended safety practices.
- Before starting: Check all setscrews for tightness and rotate wheel by hand to make sure it has not moved in transit.

| Relubrication Schedule (Months)* Spherical Roller Bearing - Solid Pillow Blocks | | | | | | | | | |
|--|-------------|-------|-------|------|------|------|------|------|------|
| Shaft DIA | Speed (RPM) | | | | | | | | |
| | 500 | 1000 | 1500 | 2000 | 2500 | 3000 | 3500 | 4000 | 4500 |
| 1" thru 1 7/16" (25 – 35) | 6 | 4 | 4 | 2 | 1 | 1 | 1 | 1 | 1/2 |
| 1 1/16" thru 2 3/16" (40 – 55) | 4 | 2 | 1 1/2 | 1 | 1/2 | 1/2 | 1/2 | 1/2 | 1/2 |
| 2 7/16" thru 3 7/16" (60 – 85) | 3 | 1 1/2 | 1 | 1/2 | 1/2 | 1/4 | 1/4 | | |
| 3 5/16" thru 4 5/16" (90 – 125) | 2 1/2 | 1 | 1/2 | 1/4 | | | | | |

*Suggested lubrication interval under ideal continuous operating conditions. Relubricate while running, if safety permits, until some purging occurs at seals. Adjust lubrication frequency depending on conditions of purged grease. Use one-half of listed interval for vertical shaft applications or for 24 hour operation. Hours of operation, temperature, and surrounding conditions will affect the relubrication frequency required.

- Lubricate with a high quality NLGI No. 2 lithium-base grease having rust inhibitors and antioxidant additives, and a minimum oil viscosity of 500 SUS at 100°F (38°C). Some greases having these properties are:
 Shell - Gadus S2 V100 2 Exxon - Ronex MP
 Mobil - Mobilith SHC100 Mobil - Mobilith SHC220
- Lubricate bearings prior to extended shutdown or storage and rotate shaft monthly to aid corrosion protection.

Figure 11. Safety & Lubrication Instructions for Fans with Spherical Roller Bearings with Split Pillow Block Housings

WARNING

- This equipment must not be operated without proper guarding of all moving parts. While performing maintenance be sure remote power switches are locked off. See installation manual for recommended safety practices.
- Before starting: Check all setscrews for tightness, and rotate wheel by hand to make sure it has not moved in transit.

| Relubrication Schedule (Months)* Spherical Roller Bearing - Split Pillow Blocks | | | | | | | | | | Grease to be added at each interval |
|--|-------------|-------|-------|-------|-------|-------|-------|------|------|-------------------------------------|
| Shaft DIA | Speed (RPM) | | | | | | | | | |
| | 500 | 750 | 1000 | 1500 | 2000 | 2500 | 3000 | 3500 | 4000 | |
| 1 1/16" thru 1 15/16" (35 – 50) | 6 | 4 1/2 | 4 | 4 | 3 1/2 | 2 1/2 | 2 1/2 | 1 | 1 | 0.50 oz. |
| 2 3/16" thru 2 3/4" (55 – 70) | 5 | 4 1/2 | 4 | 2 1/2 | 2 1/2 | 1 1/2 | 1/2 | 1/4 | 1/4 | 0.75 oz. |
| 2 5/16" thru 3 15/16" (75 – 100) | 4 1/2 | 4 | 3 1/2 | 2 1/2 | 1 1/2 | 1 | 1/2 | | | 2.00 oz. |
| 4 7/16" thru 4 5/16" (110 – 135) | 4 | 4 | 2 1/2 | 1 | 1/2 | | | | | 4.00 oz. |
| 5 7/16" thru 6 5/16" (140 – 180) | 4 | 2 1/2 | 1 1/2 | | | | | | | 7.00 oz. |

*Suggested lubrication interval under ideal continuous operating conditions. Remove bearing cap and observe condition of used grease after lubricating. Adjust lubrication frequency as needed. Use one-half of listed interval for vertical shaft applications or for 24 hour operation. Hours of operation, temperature, and surrounding conditions will affect the relubrication frequency required. Clean and repack bearings annually. Remove old grease, pack bearing full and fill housing reservoir on both sides of bearings to bottom of shaft.

- Lubricate with a high quality NLGI No. 2 lithium-base grease having rust inhibitors and antioxidant additives, and a minimum oil viscosity of 500 SUS at 100°F (38°C). Some greases having these properties are:
 Shell - Gadus S2 V100 2 Exxon - Ronex MP
 Mobil - Mobilith SHC100 Mobil - Mobilith SHC220
- Lubricate bearings prior to extended shutdown or storage and rotate shaft monthly to aid corrosion protection.
- Purge or remove old grease when changing lubrication brands or types.

Static Oil Lubrication

- Use only high quality mineral oil with a VG grade indicated on the customer submittal drawing.
- Static oil level should be at the center of the lower-most roller (Do not overfill.)
- Complete lubrication change should be made annually.

Bearing failure can occur from many causes. See Troubleshooting section for details.

Note: All speeds shown do not apply to all shaft sizes in that group. Consult the factory if in doubt of maximum speed for a particular bearing.

Lubrication

Proper lubrication of bearings helps assure maximum bearing life. All fans are equipped with decals indicating relubrication intervals for normal operating conditions. However, every installation is different and the frequency of lubrication should be established accordingly.

Experience has shown that airborne moisture and heavy dust will dramatically reduce the life of the bearing lubricant. If any of these adverse conditions exist, it is recommended that bearings be regreased after several days of operation. Lubrication intervals can then be adjusted based on the condition of the purged grease.

Figure 9 illustrates the decal for ball bearings, Figure 10 the decal for solid pillow block spherical roller bearings, and Figure 11 shows the decal for spherical roller

bearings with split pillow block housings. Observation of the condition of the grease expelled from unit ball or roller bearings at the time of relubrication is the best guide as to whether regreasing intervals and the amount of grease added should be altered. This observation is particularly important when bearings operate continuously over 160°F. Spherical roller bearings with split pillow block housing should be lubricated until grease purges or overheating may result. Follow the lubrication interval and amount noted in Figure 11. Spherical roller bearings with split pillow block housings should be serviced once per year. Remove cap, clean out old grease and replace, filling the bottom half of the housing 1/3 full.

Greases are made with different bases. There are synthetic base greases, lithium base, sodium base, etc. Avoid mixing greases with different bases. They could be incompatible and result in rapid deterioration or breakdown of the grease.

All bearings are filled with grease before leaving the factory. When the fans are started, the bearings may discharge excess grease through the seals for a short period of time. Do not replace the initial discharge because leakage will cease when the excess grease has worked out. Sometimes the bearing has a tendency to run hotter during this period and one should not get alarmed unless it lasts over 48 hours or gets above 220°F. When relubricating, use a sufficient amount of grease to purge the seals. Rotate bearings during relubrication where good safety practice permits.

For bearings with oil lubrication, sight gauges are installed so that a proper level can be reviewed and maintained. Sight gauges should be read with bearings not rotating.

Wheel and Shaft Maintenance

Periodically inspect the shaft and wheel for dirt buildup, corrosion, and signs of excess stress or fatigue. Clean the components and, when appropriate, apply new coatings. (Any addition of coatings or weld can create an imbalance.) Check the balance of the assembly.

Structural Maintenance

All structural components or devices used to support or attach the fan to a structure should be checked at regular intervals. Vibration isolators, bolts, foundations, etc., are subject to failure from corrosion, erosion, and other causes. Improper mounting can lead to poor operation characteristics or fan fatigue and failure.

Check metallic components for corrosion, cracks, or other signs of stress. Concrete should be checked to ensure the structural integrity of the foundation.

Troubleshooting Guidelines

Use current safety practices when investigating fan or system performance problems. General safe practices and performance troubleshooting guidelines can be found in AMCA Publications 410 and 202, respectively. Fan application and field measurement procedures can be found in AMCA Publications 201 and 203.

Troubleshooting Performance Problems

The lists below indicate possible areas to check when air or sound values do not match expectations. Most fan problems can be pinpointed to one of these common causes.

Air Capacity Problems:

1. Resistance of system not at design rating. If resistance is lower than expected, both airflow and horsepower may be up. If resistance is higher than anticipated, air volume will be down.

2. Fan speed is not at design speed.
3. Air density not at design values. Also check air performance measurement techniques/procedures.
4. Devices for air modulation are closed or plugged. Also check filters.
5. Wheel mounted improperly or is rotating in reverse.
6. Parts of system or fan have been damaged or need cleaning.

Noise Problems:

1. Air performance is incorrect and fan is not at design point of operation. Fan forced to operate in an unstable flow region.
2. Bearing failure. Check bearings (lubrication).
3. Supply voltage high or inconsistent supply frequency. Adjustable frequency controllers can generate motor noise.
4. Objects which are installed in a high velocity air-stream can generate noise. This includes flow sensors, turning vanes, etc.
5. Poor fan inlet conditions.
6. Acoustics or sound measurement procedure incorrect.

Vibration Problems:

1. Misalignment of drive components.
2. Poor foundations or mounting structure (resonances).
3. Foreign material attached to rotating components.
4. Damaged rotating components (bearings, shaft, fan, wheel, sheaves).
5. Broken, loose or missing setscrews.
6. Loose bolts.
7. Vibration transmitted by another source.
8. Water accumulating in airfoil blades.
9. Fan is operating in stall or unstable flow region.

NOTE: All fans manufactured by Twin City Fan & Blower are factory balanced prior to shipment. Handling and movement of the fan during shipment may cause the rotating assembly to shift. Balance should be checked once the fan is installed. If a final trim balance is required, it is the end user's responsibility to bring the fan back to factory specifications. Final trim balancing is not the responsibility of Twin City Fan & Blower. Refer to Figure 12 for vibration guidelines.

Figure 12. Vibration Guidelines

| Condition | Fan Application Category | Rigidly Mounted mm/s (in./s) | Flexibly Mounted mm/s (in./s) |
|-----------|--------------------------|------------------------------|-------------------------------|
| Start-up | BV-3 | 6.4 (0.25) | 8.8 (0.35) |
| | BV-4 | 4.1 (0.16) | 6.4 (0.25) |
| Alarm | BV-3 | 10.2 (0.40) | 16.5 (0.65) |
| | BV-4 | 6.4 (0.25) | 10.2 (0.40) |
| Shutdown | BV-3 | 12.7 (0.50) | 17.8 (0.70) |
| | BV-4 | 10.2 (0.40) | 15.2 (0.60) |

Value shown are peak velocity, mm/s (inches/s), Filter out.

Table taken from ANSI/AMCA Standard 204-05, Table 6.3.

AMCA defines BV-3 for applications up to 400 HP; BV-4 for applications over 400 HP.

Motor Problems:

1. Incorrect wiring.
2. Speed of fan too high.
3. Parts improperly installed - binding.
4. Bearings improperly lubricated.
5. WR² capability of motor too low for application.
6. Protection devices may be improperly sized.

Drive Problems:

1. Belts improperly tensioned.
2. Drive alignment is poor.

Bearing Problems:

Generally speaking, Twin City Fan & Blower uses three types of bearings:

1. Ball bearing with set screw lock.
2. Spherical roller bearings with set screw lock.
3. Spherical roller bearings with adapter lock/taper lock feature to attach them to the shaft.

Ball bearings – These are self-aligning bearings and should present no alignment problems with one exception: i.e., on Sealmaster bearings there is a pin beneath the grease fitting which prevents the bearings outer race from rotating. Should this pin jam, the bearing loses its alignment feature.

Common failure causes are (1) set screws loosening and shaft turning within the bearing, and (2) crowned bearing supports. Loosen one bolt and measure the clearance between the pillow block and the support. Add shim to compensate.

Spherical Roller Bearings with Set Screw Lock – The self-aligning characteristic of these bearings are inherent in the spherical roller design. The closer that these bearings are to perfect alignment, the cooler they will operate.

Common failure causes are the same as with ball bearings, mainly set screws loosening and crowned bearing supports.

Spherical Roller Bearings with Adapter Lock – Again, the self-aligning feature is inherent in the spherical design. Good alignment results in a cooler operating bearing. The faster the bearing operates the more critical this becomes.

A common cause of failure is improper installation practice. Removing too much clearance from the bearing can result in preloading the bearing, resulting in premature failure; and removing not enough can result in the shaft rotating within the bearing. Properly tightened, this method of attaching a bearing to a shaft is second only to a press fit. Crowned bearing supports can also preload these bearings and should be checked by loosening one side of the bearing and checking for clearance.

Lubrication – The major cause of bearing failure is contamination of grease, insufficient grease, or incompatibility of grease. If a fan is to be stored for any length of time at the job site, the bearings immediately should be filled with grease while rotating the shaft and then the bearings should be regreased and rotated monthly. This will prevent moisture, which condenses within the bearing, from corroding the raceways. Most greases used on fan pillow blocks are lithium base. Use the greases shown on the bearing decal. Do not mix the bases without completely purging out the initial grease.

Initially, follow the lubrication instruction on the side of the fan. The frequency of lubrication should be adjusted depending on the condition of the old grease being purged. This is the responsibility of the user. If the grease is dirty, the lubrication frequency should be more often.

- a. Noise – If a bearing is increasing in noise intensity and/or vibration, it will probably result in failure.
- b. Temperature – If a bearing temperature begins to gradually rise, it will generally result in failure. A bearing can operate up to 200 degrees and operate satisfactorily if the temperature remains constant and the bearing receives adequate lubrication. Remember that a roller bearing under the same load and speed

will be somewhat more noisy and run warmer than a ball bearing. This is normal.

Rough handling and/or dropping a fan can result in brinelling the bearing. This appears as a clicking noise at first, then gradually worsens until failure.

When replacing a bearing, always align the bearings first, then bolt the pillow blocks to their support, rotate the shaft, fasten the bearings to it. If the bearing is fastened to the shaft first, tightening the pillow block bolts may bind the shaft and preload the bearings.

Limitation of Warranties and Claims

Seller warrants to the original purchaser that the goods sold hereunder shall be free from defects in workmanship and material under normal use and service (except in those cases where the materials are supplied by the buyer) for a period of one year from the date of original installation or eighteen (18) months from the date of shipment, whichever occurs first. The liability of seller under this warranty is limited to replacing, repairing, or issuing credit (at cost, F.O.B. factory and at seller's discretion) for any part or parts which are returned by buyer during such period provided that:

- a. seller is notified in writing within ten (10) days following discovery of such defects by buyer, or within ten (10) days after such defects should reasonably have been discovered, whichever is less;
- b. the defective unit is returned to seller, transportation charges prepaid by buyer.
- c. payment in full has been received by seller or said products; and
- d. seller's examination of such unit shall disclose to its satisfaction that such defects have not been caused by misuse, neglect, improper installation, repair, alteration, act of God, or accident.
- e. seller cannot guarantee sound pressure levels or dBA.

No warranty made hereunder shall extend to any seller product whose serial number is altered, effaced or removed. Seller makes no warranty, express or implied, with respect to motors, switches, controls, or other components of seller's product, where such components are warranted separately by their respective manufacturers. THIS WARRANTY IS EXPRESSLY IN LIEU OF ALL OTHER WARRANTIES, EXPRESS OR IMPLIED, WHETHER STATUTORY OR OTHERWISE, INCLUDING ANY IMPLIED WARRANTY OF MERCHANTABILITY OR FITNESS FOR A PARTICULAR PURPOSE. In no event shall seller be liable to buyer for indirect, incidental collateral, or consequential damages of any kind. (BUYER'S FAILURE TO PAY THE FULL AMOUNT DUE WITHIN SIXTY (60) DAYS OF DATE OF INVOICE SHALL OPERATE TO RELEASE SELLER FROM ANY AND ALL LIABILITY OR OBLIGATION ARISING PURSUANT TO ANY WARRANTY, EXPRESS OR IMPLIED, WHETHER STATUTORY OR OTHERWISE, INCLUDING ANY IMPLIED WARRANTY OR MERCHANTABILITY OR FITNESS FOR A PARTICULAR PURPOSE, MADE IN CONNECTION WITH ANY CONTRACT FORMED HEREUNDER. BUYER AGREES THAT SUCH FAILURE TO PAY SHALL CONSTITUTE A VOLUNTARY WAIVER OF ANY AND ALL SUCH WARRANTIES ARISING PURSUANT TO SUCH CONTACT.)

TWIN CITY FAN & BLOWER | WWW.TCF.COM

5959 Trenton Lane N | Minneapolis, MN 55442 | Phone: 763-551-7600 | Fax: 763-551-7601